

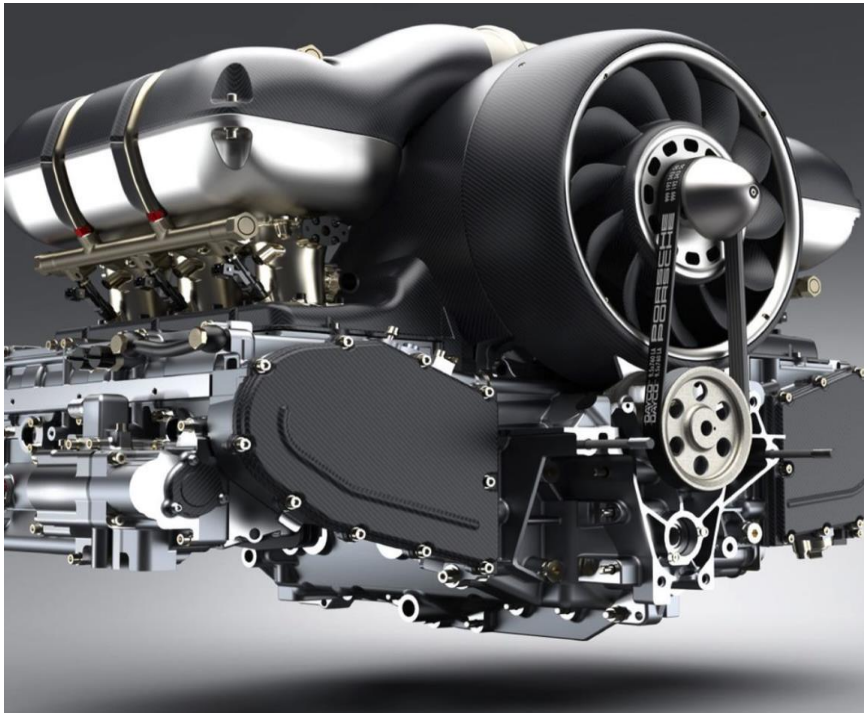

**ΠΑΝΕΠΙΣΤΗΜΙΟ ΠΕΛΟΠΟΝΝΗΣΟΥ
ΣΧΟΛΗ ΜΗΧΑΝΙΚΩΝ
ΤΜΗΜΑ ΜΗΧΑΝΟΛΟΓΩΝ ΜΗΧΑΝΙΚΩΝ**

ΠΤΥΧΙΑΚΗ ΕΡΓΑΣΙΑ

**« Οι Μηχανές Εσωτερικής Καύσης Αυτοκινήτων Στην
Αγγλική Βιβλιογραφία »**



**ΣΠΟΥΔΑΣΤΗΣ: ΚΩΝΣΤΑΝΤΙΝΟΣ ΣΠΥΡΟΥ ΑΜ: 7462
ΕΠΙΒΛΕΠΟΥΣΑ ΚΑΘΗΓΗΤΡΙΑ: ΔΟΥΣΜΠΗ ΒΑΣΙΛΙΚΗ, Μ.Εδ.
ΕΠΙΚΟΥΡΟΣ ΚΑΘΗΓΗΤΡΙΑ**

ΠΑΤΡΑ 2022-2023

ΠΡΟΛΟΓΟΣ

Η παρούσα διπλωματική εργασία εκπονήθηκε στο Τμήμα Μηχανολόγων Μηχανικών Τ.Ε. του Πανεπιστημίου Πελοποννήσου και αναφέρεται ως «Internal combustion engines» ή «Μηχανές εσωτερικής καύσης».

Θα ήθελα να ευχαριστήσω την επιβλέπουσα επίκουρο καθηγήτρια Δούσμη Βασιλική για την παρούσα διπλωματική εργασία. Επιπλέον, θα ήθελα να ευχαριστήσω την οικογένεια και τους φίλους μου.

ΣΚΟΠΟΙ ΚΑΙ ΣΤΟΧΟΙ

Πρωταρχικός στόχος αυτής της διπλωματικής εργασίας είναι η κριτική ανάλυση και αξιολόγηση της υπάρχουσας βιβλιογραφίας για τους κινητήρες εσωτερικής καύσης αυτοκινήτων στην αγγλική γλώσσα. Με αυτόν τον τρόπο, η διατριβή στοχεύει να παρέχει μια ολοκληρωμένη επισκόπηση της εξέλιξης αυτής της τεχνολογίας, των βασικών στοιχείων της και της λειτουργίας τους. Επιπλέον, η έρευνα στοχεύει στον εντοπισμό των βασικών προκλήσεων που αντιμετωπίζουν οι κινητήρες εσωτερικής καύσης αυτοκινήτων όσον αφορά τη βιωσιμότητα, την απόδοση και τον έλεγχο των εκπομπών και να διερευνήσει πιθανές λύσεις σε αυτές τις προκλήσεις. Ο απώτερος στόχος είναι η δημιουργία νέων γνώσεων και συστάσεων που μπορούν να συμβάλουν στην ανάπτυξη πιο βιώσιμων, αποδοτικών και φιλικών προς το περιβάλλον κινητήρων εσωτερικής καύσης στο μέλλον.

Για την επίτευξη αυτών των στόχων, είναι σημαντική μια σειρά από βήματα όπως η διεξαγωγή μιας συστηματικής ανασκόπησης της βιβλιογραφίας για τους κινητήρες εσωτερικής καύσης των αυτοκινήτων στην αγγλική γλώσσα, συμπεριλαμβανομένων ακαδημαϊκών άρθρων, βιβλίων κ.λπ. Σημαντικός επίσης είναι και ο προσδιορισμός των βασικών στοιχείων των κινητήρων εσωτερικής καύσης, συμπεριλαμβανομένων των εμβόλων, των κυλίνδρων, των βαλβίδων, των συστημάτων έγχυσης καυσίμου και των συστημάτων εξάτμισης και η ανάλυση των λειτουργιών, των αρχών σχεδιασμού και των χαρακτηριστικών απόδοσης.

Επιπρόσθετη επίτευξη των στόχων αποτελεί η αξιολόγηση της ιστορικής εξέλιξης των κινητήρων εσωτερικής καύσης, συμπεριλαμβανομένης της ανάπτυξης νέων τεχνολογιών όπως η υπερσυμπίεση, ο άμεσος ψεκασμός και ο μεταβλητός χρονισμός των βαλβίδων, καθώς και η αξιολόγηση του αντίκτυπού τους στην απόδοση του κινητήρα και τις εκπομπές των ρύπων.

Η ανάλυση των βασικών προκλήσεων που αντιμετωπίζουν οι κινητήρες εσωτερικής καύσης όσον αφορά τη βιωσιμότητα, την απόδοση και τον έλεγχο των εκπομπών, συμπεριλαμβανομένων των ζητημάτων που σχετίζονται με την κατανάλωση καυσίμου, τις εκπομπές αερίων του θερμοκηπίου και την ατμοσφαιρική ρύπανση αποτελεί σημαντικό παράγοντα. Επιπρόσθετα, σημαντικές είναι και οι πιθανές λύσεις σε αυτές τις προκλήσεις, συμπεριλαμβανομένων των εναλλακτικών καυσίμων, των υβριδικών κινητήρων και των προηγμένων τεχνολογιών καύσης, και η αξιολόγηση της σκοπιμότητας, των επιδόσεων και των περιβαλλοντικών επιπτώσεών τους.

Η σύνθεση των ευρημάτων από την ανασκόπηση και την ανάλυση της βιβλιογραφίας για τη δημιουργία νέων ιδεών και προτάσεων για την ανάπτυξη πιο βιώσιμων, αποδοτικών και

φιλικών προς το περιβάλλον κινητήρων εσωτερικής καύσης στο μέλλον αποτελεί έναν από τους σημαντικούς παράγοντες επίσης.

Με την επίτευξη αυτών των στόχων, η διπλωματική θα συμβάλει στην υπάρχουσα γνώση για τους κινητήρες εσωτερικής καύσης αυτοκινήτων και θα προσφέρει πολύτιμες γνώσεις για τους υπεύθυνους χάραξης πολιτικής, τους επαγγελματίες του κλάδου και τους ερευνητές του τομέα.

Υπεύθυνη Δήλωση Σπουδαστών: Οι κάτωθι υπογεγραμμένοι σπουδαστές έχουν επίγνωση των συνεπειών του Νόμου περί λογοκλοπής και δηλώνουμε υπεύθυνα ότι είμαστε συγγραφείς αυτής της Διπλωματικής Εργασίας, έχουμε δε αναφέρει στην Βιβλιογραφία μας όλες τις πηγές τις οποίες χρησιμοποιήσαμε και λάβαμε ιδέες ή δεδομένα. Δηλώνουμε επίσης ότι, οποιοδήποτε στοιχείο ή κείμενο το οποίο έχουμε ενσωματώσει στην εργασία μας προερχόμενο από Βιβλία ή άλλες εργασίες ή το διαδίκτυο, γραμμένο ακριβώς ή παραφρασμένο, το έχουμε πλήρως αναγνωρίσει ως πνευματικό έργο άλλου συγγραφέα και έχουμε αναφέρει ανελλιπώς το όνομά του και την πηγή προέλευσης.

Ο σπουδαστής

Κωνσταντίνος Σπύρου

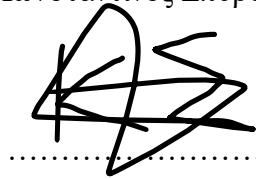
A handwritten signature in black ink, appearing to be 'K. S.', written over a horizontal dotted line.

(Υπογραφή)

ΠΕΡΙΛΗΨΗ

Η ολοκληρωμένη κατανόηση των κινητήρων εσωτερικής καύσης που παρέχεται σε αυτή τη διπλωματική υπογραμμίζει τον κρίσιμο ρόλο των κινητήρων εσωτερικής καύσης στην αυτοκινητοβιομηχανία και τον αντίκτυπό τους στο περιβάλλον και την κοινωνία. Σε ορισμένες από τις πιο σημαντικές οικονομικές αγορές, οι κινητήρες εσωτερικής καύσης έχουν αποδειχθεί αναμφισβήτητη επιτυχία, ιδιαίτερα στα ελαφρά οχήματα. Σε όλο τον κόσμο, υπάρχουν περίπου ένα δισεκατομμύριο από αυτά τα αυτοκίνητα και οι κινητήρες που τα τροφοδοτούν, και μέχρι το έτος 2020, αναμένεται ότι θα είναι περίπου δύο δισεκατομμύρια. Οι λόγοι για την επιτυχία τους περιλαμβάνουν σχετικά χαμηλό αρχικό κόστος, υψηλή πυκνότητα ισχύος, λογική αυτονομία οδήγησης, δυνατότητα ανεφοδιασμού με καύσιμα της τάξης των λεπτών σε πολλές τοποθεσίες, στιβαρότητα και ευελιξία, εύλογη απόδοση, ικανή να πληροί τα ρυθμιζόμενα όρια εκπομπών, και να ταιριάζουν καλά με τα διαθέσιμα καύσιμα. Ωστόσο, αυτές οι επιτυχίες συνοδεύονται από προκλήσεις, ιδίως όσον αφορά τη μείωση των εκπομπών και τη βελτίωση της απόδοσης του κινητήρα.

Υπήρξαν πολλές διαφορετικές παραλλαγές του κινητήρα IC όλα αυτά τα χρόνια. Υπάρχουν δύο βασικές κατηγορίες κινητήρων εσωτερικής καύσης: αυτοί που χρησιμοποιούν ανάφλεξη με σπινθήρα και αυτοί που χρησιμοποιούν ανάφλεξη με συμπίεση (ντίζελ). Σε έναν κινητήρα ανάφλεξης με σπινθήρα, η ανάμειξη καυσίμου και αέρα πρέπει να είναι (σχεδόν) συνεπής και η εξέλιξη της φλόγας πρέπει να είναι περισσότερο ή λιγότερο τακτική. Αυτό είναι ένα από τα πιο σημαντικά στοιχεία του κινητήρα. Προκειμένου αυτού του είδους η διαδικασία ανάφλεξης και καύσης να λειτουργήσει με επιτυχία, το καύσιμο πρέπει να μπορεί να αντέξει την αυτοανάφλεξη ενώ ταυτόχρονα να έχει την ικανότητα να εξατμίζεται σχετικά εύκολα. Αυτά τα χαρακτηριστικά μπορούν να βρεθούν σε μια ποικιλία καυσίμων, όπως η βενζίνη, το φυσικό αέριο, το προπάνιο και πολλοί τύποι αλκοολών.

Στους κινητήρες ανάφλεξης με σπινθήρα, ο λόγος συμπίεσης διατηρείται συχνά σε επίπεδο που θεωρείται κατάλληλο σε μια προσπάθεια να ελαχιστοποιηθεί το χτύπημα του σπινθήρα. Οι κινητήρες ανάφλεξης με σπινθήρα χρησιμοποιούνται σχεδόν σε όλα τα σημερινά ελαφρά αυτοκίνητα. Πρακτικά όλοι αυτοί οι κινητήρες λειτουργούν με στοιχειομετρικά μείγματα και χρησιμοποιούν συστήματα καταλύτη τριών κατευθύνσεων για συμμόρφωση με τους κανονισμούς ρύπανσης.

Ο κινητήρας εσωτερικής καύσης αποτελείται από μια ποικιλία διαδικασιών, οι πιο σημαντικές από τις οποίες είναι η επαγωγή, η συμπίεση, η καύση, η εκτόνωση και η εξάτμιση. Είναι δύσκολο για τον κινητήρα να επιτύχει ένα επίπεδο απόδοσης ίσο με εκατό τοις εκατό, δεδομένου ότι κάθε μία από αυτές τις διεργασίες (και οι υποδιεργασίες τους) είναι ευάλωτη σε πραγματικές συνέπειες (μη αναστρεψιμότητα και απώλειες ενέργειας). Ένα είδος απώλειας ενέργειας που εμποδίζει την επίτευξη της μέγιστης δυνατής απόδοσης είναι η μεταφορά θερμότητας από τα αέρια που βρίσκονται μέσα στον κύλινδρο.

Η εργασία ξεκινά με μια εισαγωγή στις βασικές έννοιες, συμπεριλαμβανομένου του γιατί οι κινητήρες είναι σημαντικό να μελετηθούν, οι διαφορετικοί τύποι κινητήρων, ο σχεδιασμός του κινητήρα και η ταξινόμηση και τα εξαρτήματα των κινητήρων. Το ιστορικό υπόβαθρο των κινητήρων εσωτερικής καύσης συζητείται επίσης, ακολουθούμενη από μια λεπτομερή ανάλυση των κοινών κύκλων κινητήρα, ιδανικοί κύκλοι για κινητήρες αερίου, διαμορφώσεις κινητήρα, διαμόρφωση βαλβίδων για συστήματα εισαγωγής και εξαγωγής, υπερσυμπιεστές και υπερσυμπιεστές, κινητήρες με καρμπυρατέρ, συστήματα ψεκασμού καυσίμου, συστήματα για ψύξη και θερμοδυναμικές ιδιότητες. Όλες αυτές οι πτυχές του σχεδιασμού και της απόδοσης

του κινητήρα είναι απαραίτητες για την κατανόηση του τρόπου δημιουργίας πιο αποδοτικών και φιλικών προς το περιβάλλον κινητήρων.

Το δεύτερο κεφάλαιο επικεντρώνεται στα διαγνωστικά και τη διαχείριση κινητήρα, συμπεριλαμβανομένης της διαχείρισης βενζινοκινητήρων και πετρελαιοκινητήρων, διαγνωστικών κινητήρων, ανάπτυξης συστημάτων ελέγχου και ταξινόμησης κινητήρων εσωτερικής καύσης με βάση τα συστήματα ελέγχου τους. Το κεφάλαιο εξετάζει επίσης τις πρόσφατες εξελίξεις στις τεχνολογίες διαχείρισης κινητήρων και διάγνωσης, συμπεριλαμβανομένων των συστημάτων που βασίζονται στην τεχνητή νοημοσύνη, της ανάλυσης μεγάλων δεδομένων και της ενσωμάτωσης της τεχνολογίας Διαδικτύου των πραγμάτων (IoT). Αυτές οι τεχνολογίες είναι ζωτικής σημασίας για τη βελτίωση της απόδοσης του κινητήρα και τη μείωση των εκπομπών και αναμένεται να διαδραματίσουν σημαντικό ρόλο στο μέλλον του σχεδιασμού και της ανάπτυξης του κινητήρα.

Το τρίτο κεφάλαιο διερευνά την τριβή και τη λίπανση, συμπεριλαμβανομένης της τριβής του κινητήρα, της λίπανσης, των λιπαντικών και των διαφόρων ιδιοτήτων τους, των συστημάτων λίπανσης και των διαφόρων εξαρτημάτων του κινητήρα που λιπαίνονται. Το κεφάλαιο υπογραμμίζει τη σημασία της αποτελεσματικής λίπανσης για τη μείωση της φθοράς του κινητήρα και τη βελτίωση της απόδοσης του κινητήρα. Συζητούνται επίσης οι πρόσφατες εξελίξεις στην τεχνολογία λίπανσης, συμπεριλαμβανομένων των λιπαντικών με βάση τη νανοτεχνολογία και των αυτολιπαινόμενων επιστρώσεων. Η αποτελεσματική λίπανση είναι μια ουσιαστική πτυχή του σχεδιασμού και της απόδοσης του κινητήρα και διαδραματίζει κρίσιμο ρόλο στη μείωση των εκπομπών και στη βελτίωση της απόδοσης.

Το τέταρτο κεφάλαιο επικεντρώνεται στους κινητήρες καύσης φυσικού αερίου, συμπεριλαμβανομένης της καύσης φυσικού αερίου με χρήση HCCI και της προηγμένης καύσης διπλών καυσίμων. Το κεφάλαιο εξετάζει τις δυνατότητες του φυσικού αερίου ως εναλλακτικού καυσίμου για κινητήρες εσωτερικής καύσης, τα πλεονεκτήματά του έναντι των παραδοσιακών ορυκτών καυσίμων και τις προκλήσεις που συνδέονται με τη χρήση του. Το κεφάλαιο εξετάζει επίσης τις πρόσφατες εξελίξεις στους κινητήρες φυσικού αερίου, συμπεριλαμβανομένης της χρήσης προηγμένων τεχνολογιών καύσης και της ενσωμάτωσης υβριδικών κινητήρων. Οι κινητήρες φυσικού αερίου γίνονται ολοένα και πιο σημαντικοί στην αυτοκινητοβιομηχανία και αναμένεται να διαδραματίσουν σημαντικό ρόλο στη μείωση των εκπομπών και στη βελτίωση της απόδοσης στο μέλλον.

Συμπερασματικά, αυτή η διπλωματική παρέχει μια ολοκληρωμένη κατανόηση των κινητήρων εσωτερικής καύσης αυτοκινήτων και των διαφόρων εφαρμογών, τεχνολογιών και προκλήσεων τους. Η επιτυχία των κινητήρων εσωτερικής καύσης στην αυτοκινητοβιομηχανία είναι αναμφισβήτητη, αλλά συνοδεύεται επίσης από προκλήσεις που σχετίζονται με τη μείωση των εκπομπών και τη βελτίωση της απόδοσης. Οι διάφορες πτυχές του σχεδιασμού και της απόδοσης του κινητήρα, συμπεριλαμβανομένων των κύκλων κινητήρα, των διαγνωστικών και της διαχείρισης κινητήρα, της τριβής και λίπανσης και των κινητήρων καύσης φυσικού αερίου, είναι όλες απαραίτητες για την κατανόηση του τρόπου δημιουργίας πιο αποδοτικών και φιλικών προς το περιβάλλον κινητήρων. Οι πρόσφατες εξελίξεις στις τεχνολογίες διαχείρισης και διάγνωσης κινητήρων, τεχνολογία λίπανσης και κινητήρες φυσικού αερίου αναμένεται να διαδραματίσουν σημαντικό ρόλο στο μέλλον του σχεδιασμού και της ανάπτυξης κινητήρων, καθώς προσπαθούμε να δημιουργήσουμε πιο βιώσιμους και αποδοτικούς κινητήρες για να τροφοδοτούν τα οχήματα του αύριο.

Περιεχόμενα

<i>ΠΡΟΛΟΓΟΣ</i>	<i>ii</i>
<i>ΣΚΟΠΟΙ ΚΑΙ ΣΤΟΧΟΙ</i>	<i>ii</i>
<i>ΠΕΡΙΛΗΨΗ</i>	<i>v</i>
<i>ΕΙΣΑΓΩΓΗ</i>	<i>ix</i>
CHAPTER 1: INTRODUCTION	- 11 -
1.1 BASIC CONCEPTS	- 11 -
1.1.1 Why to study engines	- 11 -
1.1.2 Different types of engines	- 12 -
1.1.3 Engine design	- 13 -
1.1.4 Heat engines	- 13 -
1.1.5 Engines classification	- 27 -
1.1.6 Components	- 28 -
1.2 HISTORICAL BACKGROUND	- 29 -
1.3 COMMON ENGINE CYCLES	- 31 -
1.3.1 Spark-Ignition Engine	- 31 -
1.3.2 Compression Ignition Engine	- 33 -
1.3.3 Two-Stroke Engine	- 34 -
1.4 IDEAL CYCLES FOR GAS ENGINES	- 35 -
1.5 ENGINE CONFIGURATIONS	- 36 -
1.6 VALVE CONFIGURATION FOR INTAKE AND EXHAUST SYSTEMS	- 37 -
1.7 SUPER AND TURBO CHARGERS	- 38 -
1.8 CARBUTERED ENGINES AND FUEL INJECTION SYSTEM	- 39 -
1.9 SYSTEMS FOR COOLING	- 39 -
1.10 THERMODYNAMIC PROPERTIES	- 39 -
CHAPTER 2: DIAGNOSTICS AND ENGINE MANAGEMENT	- 41 -
2.1 IN GENERAL	- 41 -
2.2 MANAGEMENT OF GASOLINE ENGINES	- 42 -
2.3 MANAGEMENT OF DIESEL ENGINES	- 44 -
2.4 ENGINE DIAGNOSTICS	- 46 -
2.5 CONTROL SYSTEM DEVELOPMENT	- 46 -
2.6 CLASSIFICATION OF INTERNAL COMBUSTION ENGINES BY THEIR CONTROL SYSTEMS	- 47 -
CHAPTER 3: FRICTION AND LUBRICATION	- 48 -
3.1 IN GENERAL	- 48 -
3.2 ENGINE FRICTION	- 48 -
3.3 LUBRICATION	- 50 -
3.4 LUBRICANTS AND THEIR VARIOUS PROPERTIES	- 51 -

3.5	LUBRICATION SYSTEMS.....	- 54 -
3.5.1	LUBRICATION SYSTEM FOR THE WET SUMP.....	- 55 -
3.5.2	LUBRICATION SYSTEM FOR THE DRY SUMP	- 57 -
3.5.3	SYSTEM LUBRICATION MIST.....	- 57 -
3.5.4	VARIOUS COMPONENTS OF THE ENGINE RECEIVE LUBRICATION.....	- 58 -
CHAPTER 4: NATURAL GAS COMBUSTION ENGINES		- 61 -
4.1	IN GENERAL.....	- 61 -
4.2	COMBUSTION OF NATURAL GAS USING HCCI.....	- 62 -
4.3	ADVANCED COMBUSTION OF DUAL FUELS	- 64 -
ΣΥΜΠΕΡΑΣΜΑΤΑ.....		- 68 -
ΒΙΒΛΙΟΓΡΑΦΙΑ.....		- 70 -

Λίστα σχημάτων

Figure 1:	An idea of an IC engine [1]	- 15 -
Figure 2:	Piston head [2]	- 17 -
Figure 3:	Compression ring [2]	- 17 -
Figure 4:	Oil ring [4].....	- 18 -
Figure 5:	Connecting rod [5].....	- 20 -
Figure 6:	Piston with it's crank [6].....	- 21 -
Figure 7:	Bearings [3].....	- 23 -
Figure 8:	Flywheel [7]	- 24 -
Figure 9:	Four-stroke spark-ignition engine functionality [8]	- 32 -
Figure 10:	Two-Stroke engine [8]	- 34 -
Figure 11:	Different engine types [10]	- 36 -
Figure 12:	Poppet valve.....	- 38 -
Figure 13:	Splash lubrication system [19]	- 56 -
Figure 14:	Dry sump lubrication system [20]	- 57 -
Figure 15:	Ring oiling system [21]	- 59 -

ΕΙΣΑΓΩΓΗ

Στα τέλη της δεκαετίας του 1860, δημιουργήθηκε και αναπτύχθηκε με επιτυχία ο κινητήρας εσωτερικής καύσης. Θεωρείται ως μια από τις πιο σημαντικές ανακαλύψεις του 20ου αιώνα και είχε βαθιά επίδραση στον πολιτισμό, ιδιαίτερα στην ανθρώπινη κινητικότητα. Πολλές εμπορικές τεχνολογίες έχουν αναπτυχθεί με επιτυχία με βάση τον κινητήρα εσωτερικής καύσης. Σκεφτείτε πώς η ανάπτυξη του κινητήρα εσωτερικής καύσης οδήγησε στη δημιουργία και την πρόοδο των βιομηχανιών αυτοκινήτων, φορτηγών, αεροπορικών εταιρειών και τρένων. Ο κινητήρας εσωτερικής καύσης υιοθετήθηκε και συνέχισε να χρησιμοποιείται σε διάφορους τομείς εφαρμογών λόγω του συγκριτικά χαμηλού κόστους, της πλεονεκτικής αναλογίας ισχύος προς βάρος, της υψηλής απόδοσης και των σχετικά απλών και αξιόπιστων λειτουργικών χαρακτηριστικών.

Σε αντίθεση με τους κινητήρες εξωτερικής καύσης, που καίνε καύσιμο σε ξεχωριστό καυστήρα, οι κινητήρες εσωτερικής καύσης απελευθερώνουν τη χημική ενέργεια του καυσίμου μέσα στον κινητήρα και τη χρησιμοποιούν απευθείας για μηχανική προσπάθεια. Η κύρια γεωμετρία που έχει χρησιμοποιηθεί σε κινητήρες εσωτερικής καύσης είναι η γεωμετρία παλινδρομικού εμβόλου-κύλινδρου. Ένα έμβολο σε έναν κύλινδρο ταλαντώνεται εμπρός και πίσω σε κυκλικό σχήδιο, μεταφέροντας δύναμη σε έναν κινητήριο άξονα μέσω μιας μπιέλας και συστήματος στροφαλοφόρου άξονα. Η ροή αερίου προς και έξω από τον κινητήρα ελέγχεται μέσω βαλβίδων ή θυρών. Από τα τέλη του 1800, ένας παλινδρομικός κινητήρας εσωτερικής καύσης είχε αυτή τη συγκεκριμένη ρύθμιση, η οποία περιλαμβάνει ένα διαμέρισμα κινητήρα, έμβολο, βαλβίδες, έναν στροφαλοφόρο άξονα και μια μπιέλα.

Αντιπαραβάλλοντας την αξιοπιστία, τη θερμική απόδοση και τα επίπεδα εκπομπών των σημερινών κινητήρων με εκείνα που δημιουργήθηκαν πριν από 100 χρόνια, είναι δυνατό να εντοπιστούν οι βασικές διαφορές μεταξύ των δύο. Η ανάπτυξη του κινητήρα εσωτερικής καύσης για μεγάλο χρονικό διάστημα επικεντρώθηκε στην αύξηση της θερμικής απόδοσης και στη μείωση του θορύβου και των κραδασμών. Ως αποτέλεσμα, η θερμική απόδοση έχει βελτιωθεί από επίπεδα έως και 50% τώρα σε μεταξύ 10 και 20% στις αρχές του 20ού αιώνα.

Η νομοθεσία και η επιθυμία εξοικονόμησης λειτουργικών εξόδων αυξάνουν την απόδοση των κινητήρων εσωτερικής καύσης. Το πρότυπο Ομοσπονδιακής Εταιρικής Μέσης Οικονομίας Καυσίμου (CAFE) είναι η κύρια απαίτηση χιλιομετρικών οχημάτων στις ΗΠΑ. Για μια περίοδο 20 ετών, από το 1990 έως το 2010, το πρότυπο CAFE για επιβατικά αυτοκίνητα και ελαφρά φορτηγά ήταν 27,5 μίλια ανά γαλόνι (mpg). Τα κριτήρια CAFE έχουν αυξηθεί πρόσφατα και αναμένεται να διπλασιαστούν τα επόμενα δέκα χρόνια. Θα απαιτηθεί διευρυμένη χρήση τεχνολογιών, όπως ηλεκτρονικός έλεγχος, συρρίκνωση κινητήρα, υπερσυμπίεση, υπερπλήρωση, μεταβλητός χρονισμός βαλβίδων, καύση σε χαμηλή θερμοκρασία και ηλεκτρικοί κινητήρες και κιβώτια ταχυτήτων για την κάλυψη των αυξημένων απαιτήσεων χιλιομέτρων του οχήματος.

Σε πολλούς τομείς, οι κινητήρες εσωτερικής καύσης έχουν αντικαταστήσει άλλες τεχνολογίες βασικής κίνησης. Μέχρι το 1920, οι βενζινοκινητήρες είχαν αντικαταστήσει την πλειοψηφία των ατμομηχανών ή ηλεκτρικών κινητήρων που τροφοδοτούσαν αυτοκίνητα το 1900. Μέχρι το 2020, θα υπάρχουν περίπου 220 εκατομμύρια αυτοκίνητα με κινητήρα εσωτερικής καύσης μόνο στις Ηνωμένες Πολιτείες, με 12 εκατομμύρια νέα αυτοκίνητα έτος παραγωγής. Τα πλοία και οι σιδηροδρομικές μηχανές κινούνταν με ατμομηχανές το 1900. επί του παρόντος, χρησιμοποιούνται δίχρονοι και τετράχρονοι κινητήρες ντίζελ.

Πριν από το 1950, οι εμβολοφόροι κινητήρες τροφοδοτούσαν σχεδόν όλους τους τύπους αεροσκαφών. Τα μεγάλα αεροπλάνα χρησιμοποιούν πλέον αεριοστρόβιλους ως πηγή ενέργειας, ενώ οι εμβολοφόροι κινητήρες συνεχίζουν να κυβερνούν τη βιομηχανία μικρών αεροπλάνων. Ανάλογα με τον κυβισμό τους, έχουν δημιουργηθεί κινητήρες εσωτερικής καύσης για να παράγουν ισχύ στην περιοχή από 0,01 kW έως 20 103 kW. Ανταγωνίζονται στην αγορά με ατμομηχανές, αεριοστρόβιλους και ηλεκτρικούς κινητήρες. Τα οχήματα, οι σιδηρόδρομοι, τα πλοία, η αεροπορία, η σταθερή ενέργεια και η οικιακή χρήση είναι οι κύριες εφαρμογές. Η μεγάλη πλειονότητα των κινητήρων εσωτερικής καύσης είναι κατασκευασμένη για οχήματα, τα οποία χρειάζονται απόδοση ισχύος περίπου 100 kW.

Από το 1970, έχει καταβληθεί μεγάλη προσπάθεια για τη μείωση των διαφόρων εκπομπών από τους κινητήρες, καθώς οι περιβαλλοντικές ανησυχίες, συμπεριλαμβανομένης της επίδρασης της κακής ποιότητας του αέρα στην υγεία, έχουν αποκτήσει εξέχουσα θέση. Οι εκπομπές από τους κινητήρες εσωτερικής καύσης είναι τώρα μόνο περίπου το 5% αυτών που ήταν πριν από 40 χρόνια. Ένα από τα βασικά ζητήματα στο σχεδιασμό και τη λειτουργία των κινητήρων εσωτερικής καύσης σήμερα είναι η τήρηση των κανονισμών εκπομπών ρύπων. Τα οξειδία του αζώτου (NO_x), το μονοξείδιο του άνθρακα (CO), οι υδρογονάνθρακες (HC), τα σωματίδια (PM) και οι αλδεΐδες είναι οι κύριοι ρύποι από τις μηχανές εσωτερικής καύσης.

Δεδομένου ότι το διοξείδιο του άνθρακα (CO_2) είναι η κύρια αιτία της κλιματικής αλλαγής, οι εκπομπές των κινητήρων εσωτερικής καύσης που τροφοδοτούνται από υδρογονάνθρακες υπόκεινται πλέον σε ρύθμιση. Η χρήση υδρογόνου και αμμωνίας ως καυσίμων κινητήρων εσωτερικής καύσης χωρίς άνθρακα κερδίζει δημοτικότητα

CHAPTER 1: INTRODUCTION

1.1 BASIC CONCEPTS

1.1.1 Why to study engines

In some of the most important economic markets, internal combustion engines have proven an unequivocal success. The internal combustion engine (IC engine) has unquestionably been very successful in its role as the driving force behind light-duty vehicles. Around the globe, there are around one billion of these automobiles and the engines that power them; by the year 2020, it is anticipated that there will be approximately two billion. These are extraordinary statistics, considering the magnitude and complexity of the gadget. Other uses for internal combustion engines include the production of stationary electricity, the propulsion of marine vessels, small utility vehicles, off-road vehicles, and use in agriculture.

It has been thoroughly investigated and recorded why internal combustion engines have been so successful. These reasons include relatively low initial costs, high power density, a reasonable driving range (for example, more than 200 miles for a standard fuel tank size), the ability to refuel on the order of minutes at many locations, being robust and versatile, being reasonably efficient, being capable of meeting regulated emission limits, and being well matched to available fuels. This last component is extremely significant, since it is the cause of several of the other appealing characteristics.

Fuels derived from liquid hydrocarbons (like gasoline and diesel, for example) have a relatively high energy density, are somewhat safe and stable, and can be found in plenty at the present time. In addition, the combustion methods that are used by spark-ignited engines and compression-ignited engines both make great use of the features that these fuels possess.

The engine technology that is available today encompasses a broad spectrum, from quite simple to relatively sophisticated. Carburetors, mechanical valve systems, and huge displacements are still common features in certain modern engines, although not all of them. Direct fuel injection, variable valve timings, turbocharging, and the ability to disable certain cylinders for part-load operation are some of the features that are included in more sophisticated engine designs. The vast majority of spark-ignition engines are built to operate at or near stoichiometric with compression ratios that are lower than around 11 (to avoid spark knock).

The perception that the internal combustion engine (IC engine) is based on "ancient" technology contributes to the fact that its potential extinction is often discussed in the popular press. In spite of this common misconception, the internal combustion engine (IC engine) continues to be a useful tool. Electric motors that are powered by batteries or fuel cells are examples of alternative power plants that may be used in light-duty cars. There have been some strides made in the development of these technologies, but it will be several years before we can replace the internal combustion engine with one of these alternatives. It is anticipated that internal combustion engines will continue to be the most common kind of power plant for a good number of decades into the foreseeable future. This is especially true when you think about how long it will take to replace the cars already in the fleet.

1.1.2 Different types of engines

There are several distinct iterations of the IC engine. Engines that use spark ignition and engines that use compression ignition (diesel) make up the two primary groups. An essential component of the spark-ignition engine is a (almost) uniform mixing of fuel and air, as well as a more or less ordered flame propagation. In order for this kind of ignition and combustion process to work well, the fuel has to be able to evaporate relatively readily while also being able to withstand autoignition. Gasoline, natural gas, propane, and other alcohols are examples of fuels that possess these qualities. In order to prevent spark knock in the spark-ignition engine, the compression ratio is often kept at a reasonable level. To comply with pollution rules, almost all of today's light-duty cars use spark-ignition engines, and almost all of those engines run with stoichiometric mixtures and employ three-way catalyst systems.

The compression-ignition engine, on the other hand, relies on the injection of gasoline into a cylinder that also contains air, as well as on the fuel's ability to self-ignite as a result of the temperature of the compressed air. Combustion takes place at a number of different points all along the cylinder of a compression-ignition engine, but there is no coordinated flame propagation. For the compression ignition engine to work, the fuel it uses must be able to self-ignite quickly and easily. Otherwise, the process of ignition and combustion will not be satisfactory. Typically, diesel fuel is used for this purpose; however, other types of lubricants and jet fuel may also be utilized. It is customarily necessary for the compression-ignition engine to have a compression ratio that is somewhat high in order to create air that is adequately heated for the process of auto-ignition. In order to guarantee that no fuel is wasted, these engines are often required to run at a higher-than-normal air-to-fuel ratio. The power density of a compression-ignition engine may be increased in a variety of contexts by the use of intake air compression mechanisms, such as turbochargers and superchargers.

The number of strokes that an engine employs in order to produce one power event is an additional essential classification of engines. The difference between the two-stroke cycle engine and the four-stroke cycle engine is the number of strokes used during each cycle. The two-stroke cycle engine utilizes two strokes during each cycle, while the four-stroke cycle engine utilizes four strokes during each cycle. Four-stroke cycle engines are used in almost all of today's lighter-duty vehicle engines. Two-stroke cycle engines are often found in utility engines, as well as certain engines for small scooters and motorcycles.

The IC engine is not a heat engine; rather, it is a chemical conversion device, which is a more appropriate description of its function. Because of this, the "Carnot restriction" cannot be used in this situation. In fact, it is theoretically possible for the IC engine to achieve efficiencies close to 100 percent while still adhering to the first and second principles of thermodynamics.

The internal combustion engine is made up of a number of different processes, the most important of which are induction, compression, combustion, expansion, and exhaust. Because each of these processes (and their sub-processes) is susceptible to actual effects (irreversibilities and energy losses), it is impossible for the engine to achieve a level of efficiency equal to 100 percent. For instance, heat transfer from the gases contained inside the cylinder is a kind of energy loss that brings down the highest achievable efficiency.

The impossibility of reversing the effects of the combustion process is an additional and more serious constraint. Energy losses may be very close to zero during the process of adiabatic conversion of chemical energy to thermal energy. However, according to the second law of thermodynamics, this process cannot be reversed in any significant way, and as a consequence, a lesser quality of energy is produced along with a loss of the ability to create work. This thermodynamic reality, and not the so-called "Carnot constraint," is what ultimately limits the efficiency of internal combustion engines.

1.1.3 Engine design

Today's engines must accomplish multiple tasks at once in order to be effective. Although the manner in which they are stressed varies from one application to the next, all market sectors recognize, at least to some extent, the significance of these aims. These objectives include achieving an acceptable level of performance (in terms of both power and torque), a high level of efficiency, a cheap starting cost, the ability to comply with pollution rules, an acceptable level of reliability, and low levels of maintenance. In addition, the ability of the engine to function on two or more fuels is considered important in some market areas. This is referred to as fuel adaptability. Obviously, in order to accomplish these objectives, the process of designing and manufacturing effective internal combustion engines has to be labor- and resource-intensive.

The following comparison of the heavy-duty truck market and the light-duty automotive market serves as an example of the various ways in which these goals are emphasized for different applications. Specifically, the comparison highlights the ways in which these goals are emphasized in light-duty vehicles. When it comes to the market for heavy-duty trucks, other factors, such as engine performance and efficiency, often take precedence. On the other hand, when it comes to the market for light-duty trucks, the initial cost may be the primary issue. It is possible to point to analogous distinctions in each of the other market sectors as well. Before the engine can be sold, it must meet all emission requirements.

1.1.4 Heat engines

A heat engine may be defined as any form of engine or machine that extracts heat energy from the burning of fuel or any other source and turns this heat energy into mechanical effort. Heat can be extracted from a variety of sources, including nuclear reactors.

The following are the two primary categories that may be applied to heat engines:

- External Combustion Engines
- Engines that run on internal combustion

Engines with an external combustion (E.C. engines)

In this scenario, the combustion of the fuel occurs outside of the cylinder, similar to how it happens in steam engines. In steam engines, the heat created by the combustion process is utilized to produce steam, which is then used to drive a piston inside a cylinder. There are also

things like hot air engines, steam turbines, and closed-cycle gas turbines that are examples of external combustion engines. These engines are often used for a variety of purposes, including the propulsion of trains and ships as well as the generation of electric power.

Internal combustion engines (also known as I.C. engines)

In this kind of engine, the combustion of the fuel with the oxygen that is present in the air takes place inside the cylinder of the engine. Engines that use mixtures of combustible gases and air are referred to as "gas engines". Engines that use lighter liquid fuels or "spirit" are referred to as "petrol engines", and engines that use heavier liquid fuels are referred to as oil compression ignition or diesel engines. All of these types of engines fall under the category of internal combustion engines.

In comparison to external combustion engines, reciprocating internal combustion engines have a number of benefits, including the following:

- There is a high level of efficiency overall.
- A simplification of the mechanical process.
- The ratio of weight to power is often rather low.
- Initial costs are often cheaper on average.
- Ability to start quickly despite the frigid circumstances.
- Because of their small size, these units demand much less floor space.

Here are some of the things that people say are better about external combustion engines than internal combustion engines:

- The torque required to start a vehicle is often rather high.
- Since the fuel is burned outside of the vehicle, more cost-effective fuels may be employed. Even solid fuels have their uses, especially in certain situations.
- The burning of fuel on the outside of the device makes it possible to have flexibility in the arrangement.
- These units may start themselves with the working fluid, in contrast to internal combustion engines, which need some extra equipment or mechanisms in order to be started.

Figure 1 illustrates the fundamental concept of an internal combustion engine. The fuel and air mixture is poured into the cylinder until it is almost full, and then the other end is sealed up. The cylinder is pushed forward by the crankshaft as it rotates. As a result of the piston being thrust upward, the mixture at the top of the cylinder is compressed. The mixture is ignited, and as it burns, it generates a gas pressure that exerts a downward force on the piston as it travels through the cylinder. The motion shown by the arrow numbered "1" is this one. The piston exerts force on the rod, which in turn forces it to exert force on the crank. As seen by the arrow labeled "2," a rotary (turning) motion is imparted onto the crank. The flywheel that is attached to the end of the crankshaft not only stores energy but also maintains a consistent rotation of the crank.

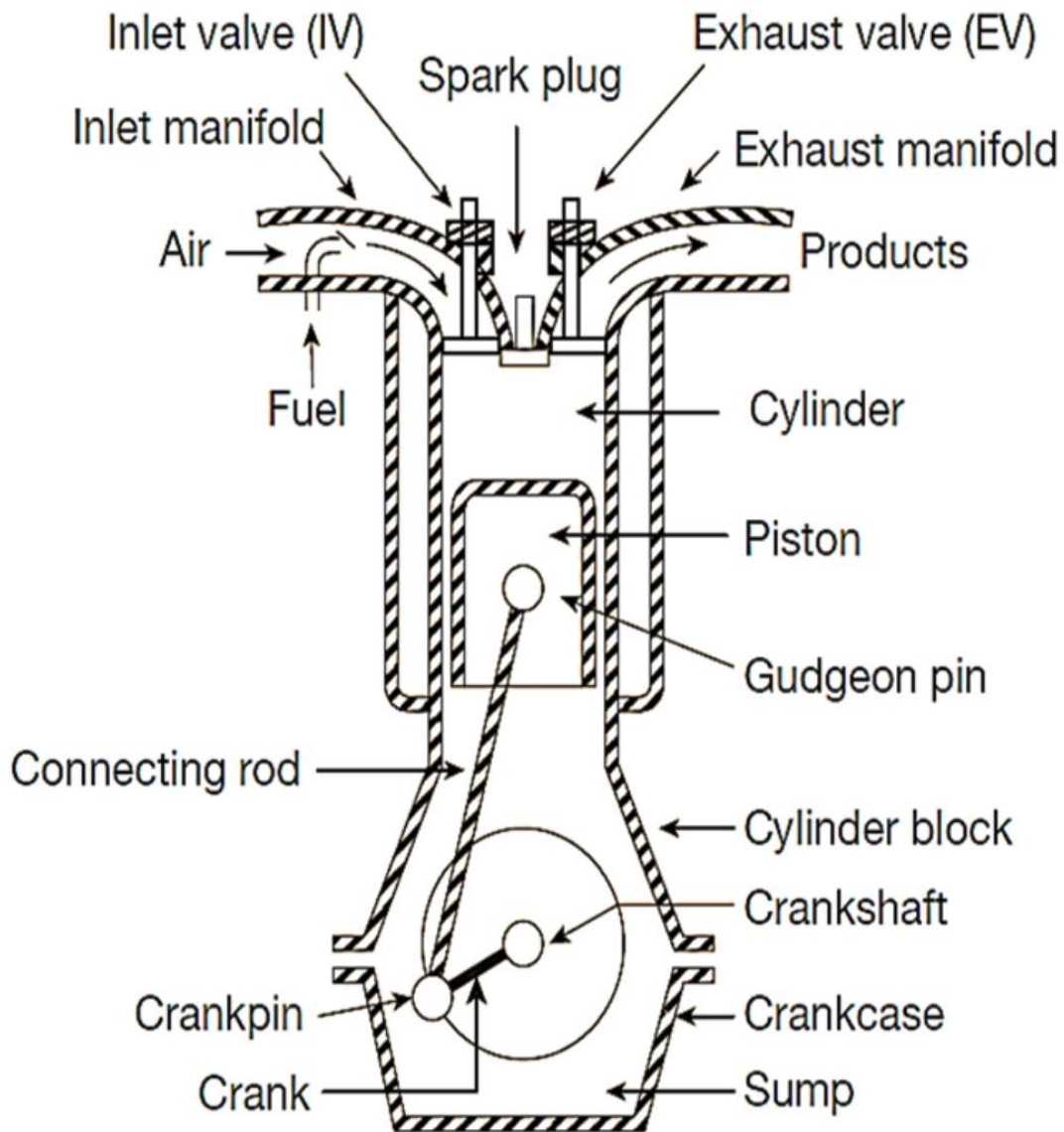

Figure 1: An idea of an IC engine [1]

The various components of an internal combustion engine are broken down into their individual descriptions in the following paragraphs.

Components that are shared by both gasoline and diesel engines:

- Cylinder
- Cylinder head
- Piston
- Piston rings
- Gudgeon pin
- Connecting rod
- Crankshaft
- Crank
- Engine bearing

- Crankcase
- Flywheel
- Governor
- Valves

Components for only gasoline engines:

- Spark plugs
- Carburettor
- Fuel pump

Components for only diesel engines:

- Fuel pump
- Injector

The gas that is under pressure is contained in the cylinder, which also acts as a guide for the piston. Because it comes into such close proximity with the byproducts of combustion, it has to be cooled. A simple cylindrical barrel is the right shape for this component; the piston would glide inside of it. The movement of the piston, also known as the stroke, is typically longer than the bore of the cylinder. This dimension is referred to as the "stroke bore ratio." The top end is made up of a clearing space or a combustion space, both of which are areas in which the ignition and burning of the charge take place. In actuality, it is necessary to deviate from the ideal hemispherical slope in order to provide room for the valves, spark plugs, and other components that are needed to regulate the combustion process. The cylinder is typically produced from high-grade cast iron and is poured as a single piece during the casting process.

A detachable cylinder head is used to seal off one of the ends of the cylinder, which is cooled by water. Typically, an inlet or admission valve and an exhaust valve are included in the combustion chamber. These valves allow the mixture of air and fuel to be admitted, and they allow the product of combustion to be discharged. Cams that are geared to the engine shaft are responsible for maintaining the closed position of two valves. Ports are the terms used to describe the passageways in the cylinder head that lead to and from the valves. The term "inlet manifold" refers to the group of pipes that link the individual intake ports of the numerous cylinders to a single intake pipe that serves the whole engine. The term "exhaust manifold" refers to the system of pipes that is used when the exhaust ports are linked in the same manner as a common exhaust system. On cover head valve engines, the primary function of the cylinder head is to ensure that the working ends of the cylinders are hermetically sealed, as opposed to allowing the entrance and departure of gases. The internal cavity of the head is referred to as the combustion chamber, and it is into this space that the mixture is packed in order to be fired. Because of its form, it controls both the direction and the pace of combustion. In order to accommodate the ignition spark plug, the cylinder heads are drilled and tapped with the appropriate thread. It is essential that every combustion chamber in an engine have precisely the same size and shape. The shape of the piston could have some influence on the overall form. Cast iron or aluminum are the typical materials used to make the cylinder head.



Figure 2: Piston head [2]



Figure 3: Compression ring [2]



Figure 4: Oil ring [4]

Each cylinder has a piston attached to its face in order to accept the pressure from the gas and send that pressure to the connecting rod. The piston must meet the following requirements: (i) it must be able to provide a gas-tight seal to the cylinder via the bore; (ii) it must glide easily; (iii) it must be light; and (iv) it must be strong. During the power stroke, the force acting on the piston during the compression stroke makes an effort to rotate it to the side while the connecting rod moves laterally. This lateral force necessitates that the wall of the piston, also known as the skirt, be of sufficient strength to withstand it. Because of their need to be lightweight, pistons are often composed of cast iron or an aluminum alloy. Because pistons made of light alloys expand more than those made of cast iron when the engine is cold, they need larger clearances to the bore or other specific expansion provisions. Pistons may be a plain skirt or a split skirt.

In order for the piston to move freely inside the cylinder, the fit should be quite sloppy. If it were a tight fit, it would expand as it became hotter, which may cause it to get stuck in the cylinder if it were a snug fit. If a piston becomes stuck, the engine might be completely destroyed. On the other hand, if there is an excessive amount of space between the cylinder walls and the piston, a significant portion of the pressure created by the combusting gasoline vapor will be lost via the piston. This indicates that the force applied to the piston will have a considerably smaller impact than before. The force that is applied to the piston is what causes the engines to produce their power.

Pistons are outfitted with piston rings, which serve the purpose of providing a good sealing fit between the piston and the cylinder. Cast iron with a fine grain and strong elasticity, which is unaffected by the working heat, is the material that is often used to make the rings. Some of the rings are made of a spring steel alloy. They feature a slit in one point so that they may be stretched, slid over the end of the piston, and then fitted into ring grooves that have been carved in the piston. This slit allows them to be used in an internal combustion engine. The rings are forced into the grooves that have been carved specifically for them in the piston before it is put

in the cylinder. The rings are forced into the ring grooves during the process of installing the piston in the cylinder, which results in the split ends of the rings coming very close to meeting. The rings have a snug fit on the cylinder wall and against the sidewalls of the ring grooves in the piston, which are both located in the cylinder. As a result, a strong seal is created between the cylinder wall and the piston by these components. The rings may expand or touch one another as the temperature changes, and the trade will still be profitable. As a result, they are unrestricted in their ability to climb and descend the cylinder wall.

The pressure that is above the piston may be seen as arrows moving through the space that is available between the piston and the cylinder wall. As the arrows indicate, it applies pressure not only to the front but also to the back of the piston rings as it descends. As a result, the piston ring is forced to make a firm contact with the piston ring groove's base. As a direct consequence of this, there are effective seals at each of these junctures. The better the seal, the higher the pressure in the chamber where the combustion takes place should be.

Two rings can be found on the piston of smaller engines that operate on a two-stroke cycle. Each of these is a compression ring. Two rings are utilized so that the task of maintaining the compression pressure and the combustion pressure can be split between them. This results in greater sealing while reducing the amount of pressure that the ring exerts on the cylinder wall.

Engines that use the four-stroke cycle include an additional ring that is referred to as the oil control ring. Engines that use the four-stroke cycle are built in such a way that they deposit much more oil in the cylinder wall than do engines that use the two-stroke cycle. This excess oil has to be scraped out so that it does not make its way into the combustion chamber, where it would catch fire and create all sorts of problems.

The compression rings have a rectilinear cross-section, and the oil rings have a groove in the center and through holes that are located at specific intervals from each other. The oil that has been collected from the cylinder walls runs through these holes into the piston groove, and from there it flows down the holes in the body of the piston, down the inner walls of the piston, and into the crankcase of the engine.

These are parallel spindles made of hardened steel that are inserted through the piston bosses as well as any tiny end bushes or eyes in order to make it possible for the connecting rods to swivel. When the pistons are cool, the gudgeon pins are pressed into the piston bosses of the light alloy pistons. The piston should be soaked in hot water or hot oil before removal or installation. This expands the bosses, allowing the pins to be withdrawn or installed easily and without causing harm to the piston. Since it is a component that moves back and forth, it is made hollow to reduce its weight.

The connecting rod is responsible for transferring the load from the piston to the crank, which in turn causes the crank to rotate. This results in the reciprocating motion of the piston being converted into a rotating motion of the crankshaft. The "crank pins" allow the connecting rod's lower end, often known as the "large end," to rotate. Nickel, chrome, and chrome vanadium steels are used in the construction of the connecting rods. Aluminum could be used for the construction of smaller engines.

Within the cylinder, the piston travels both upward and downward. This kind of motion, which involves going up and down, is known as reciprocating motion. The motion of the piston is consistent and linear. In the majority of machines, the motion in a straight line must first be

converted into a rotary, or turning, motion before it can be of any use. Wheels need to revolve, a cutting blade has to spin, and a pulley needs to rotate in order to function properly. A crank and connecting rod are used in order to convert the motion from one of reciprocation to one of rotation. The piston is attached to the crank by means of the connecting rod.



Figure 5: Connecting rod [5]

A component of the crankshaft is referred to as the crank. The forces that are delivered by the pistons to the connecting rods are transferred via the crankshaft of an internal combustion engine to the crankshaft of the engine. The crankshaft is connected in some way or another to each of the engine's auxiliary systems that use a mechanical transmission. Forgings are often made out of steel, but some manufacturers prefer to work with certain kinds of cast iron, such as spheroidal graphitic or nickel alloy castings, since they are less expensive to create and have a long service life. The motion of the crankshaft is what changes the reciprocating motion into a rotational motion. It is possible for the crankshaft to freely revolve thanks to the bearings that surround the journals and in which it is mounted.

The number of cylinders, as well as their placement relative to one another, as well as the direction in which the engine rotates, all have an effect on the configuration of the crankshaft, also known as the mutual arrangement of the cranks.

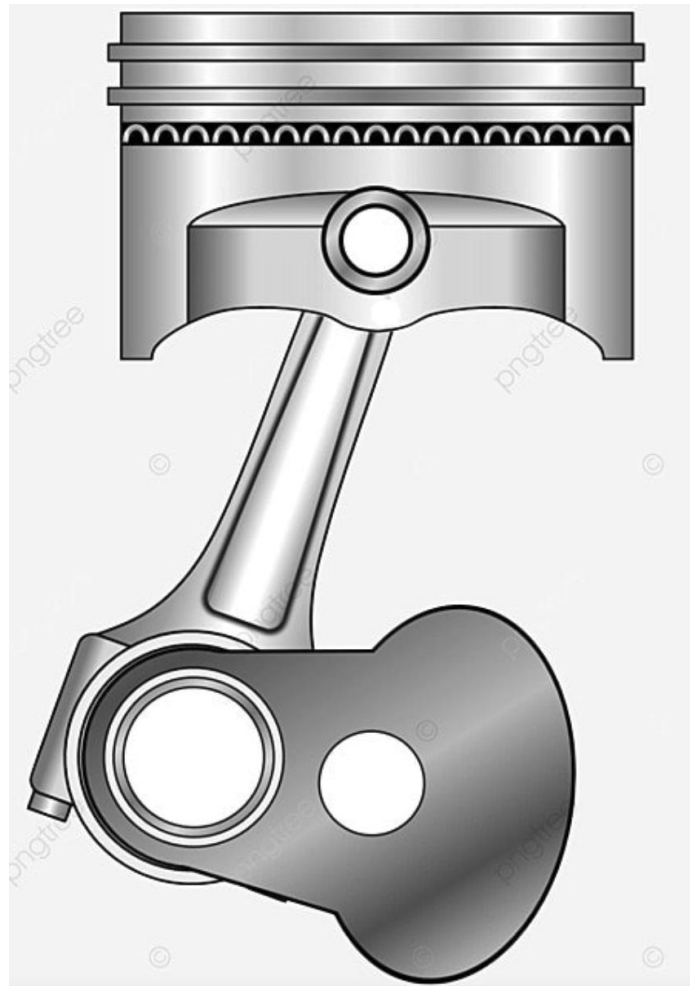

Figure 6: Piston with it's crank [6]

Bearings serve to support the crankshaft in this design. A bearing serves as the connection between the large end of the connecting rod and the crank pin on the crank of the crankshaft. In order to join the rod to the piston, a piston pin is inserted into the tiny end of the rod. Bearings allow the piston pin to move freely. Bearings are utilized to support the moving elements of the engine whenever there is rotational movement. This includes both the crankshaft and the camshaft. Bearings are meant to lessen the amount of friction between moving components so that they can do so more effortlessly. Oil is used to lubricate bearings in order to facilitate relative motion and reduce friction. There are two different kinds of bearings that may be utilized in engines: sliding and rolling.

Because they are shaped like a sleeve that may be wrapped around a rotating journal or shaft, sliding bearings are also frequently referred to as bushings or sleeve bearings. These names are sometimes used interchangeably. The connecting rod large end bearings, which are of the sleeve type and are often referred to as simply rod bearings, and the crankshaft supporting bearings, which are referred to as main bearings, are both of the split sleeve type. They have to be disassembled into their component parts before they can be installed in the engine. The bottom part of the bearing is fitted in the rod bearing cap, while the upper half of the bearing is inserted in the rod itself when it comes to the rod bearing. A finished sleeve bearing is produced when the rod cap is attached to the rod in the appropriate manner. In a similar fashion, the top parts

of the main bearings are installed in the engine first, followed by the attachment of the main bearing caps. Finally, the lower bearing halves are joined to the engine to finish the sleeve bearings that support the crankshaft.

The conventional bearing half consists of a steel or bronze back, which is then lined with a relatively soft bearing material. The lining of the bearing is what allows the bearing to function. This relatively soft bearing material, which is formed of numerous materials such as copper, lead, tin, and other metals, has the capacity to adapt to the tiny imperfections of the shaft that is spinning against it. These slight irregularities may occur when the shaft is not perfectly round. If there is any wear at all, it will be on the bearing, not the crankshaft or any other component of the engine; this allows the bearing to be changed rather than the much more expensive component.

Between the fixed support and the rotating shaft, the rolling-type bearing has balls or rollers moving back and forth. Because of the rolling contact that the balls or rollers offer, the amount of frictional resistance to movement is significantly reduced. Some roller bearings include rollers that are so minute that they are hardly larger than needles. These rollers are used in very tiny bearings. Needle bearings are the name given to certain types of bearings. Additionally, the races that the rollers ride in are tapered, and in certain roller bearings, these races are positioned at an angle to the rollers. Tapered roller bearings are the name given to these types of bearings. Some ball and roller bearings are hermetically sealed with their lubricant already in place. Those bearings can be used. These bearings don't need any additional lubrication of any kind. Others do need lubrication, either from the oil that is mixed in with the gasoline (two-stroke cycle engines) or from the lubrication system that is built into the engine itself (four-stroke cycle engines).

The configuration of the engine and the tasks that will be performed by the engine will both play a role in the designers' decision regarding the type of bearing to use in the engine. In most engine applications, sleeve bearings are utilized because they are the most common type and the most cost-effective. In fact, sleeve bearings are utilized virtually everywhere possible within automobile engines. However, there are some engines that use ball bearings and roller bearings to support the crankshaft as well as the connecting rod bearings and the piston pin bearings.

The term "crankcase" refers to the primary component of an internal combustion engine that houses the crankshaft as well as the bearings that support it. Cylinders are joined to the crankcase. This component not only keeps other components aligned but also helps to withstand the forces of the explosion and the inertia. In addition, it acts as a component of the lubrication system and shields the components from debris such as dirt.



Figure 7: Bearings [3]

The following tasks are carried out by a flywheel, which is typically made of steel or cast iron and is attached to the crank shaft:

- Moves the mechanism away from any dead centers it may have.
- It stores the energy necessary to spin the shaft while the preliminary strokes are being performed.
- Makes the rotation of the crankshaft more consistent.
- Simplifies the process of starting the engine and overcoming short time over loads, such as the scenario where the machine is started from a halted position, for example.

The type of variation in pressure determines how much weight the flywheel has, and this weight can change. When compared to its single-acting counterpart, the flywheel of a double-acting steam engine is considerably more lightweight. In a similar vein, the flywheel that is used in an engine that operates on a two-stroke cycle is much lighter than the flywheel that is used in an engine that operates on a four-stroke cycle. Flywheels for multi-cylinder engines tend to be made of lighter materials.

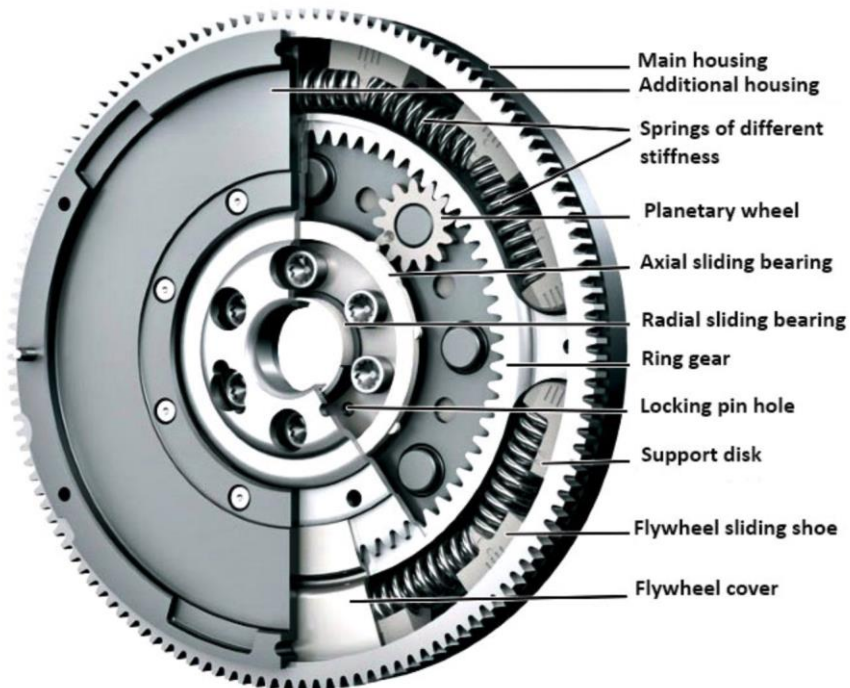

Figure 8: Flywheel [7]

One definition of a governor is a device that automatically regulates the output of a machine by controlling the amount of working fluid that is supplied to the machine. The supply valve is opened by a mechanism that is controlled by the governor if the speed of the engine lowers as a result of an increase in load. As a result, the engine accelerates back up to its initial speed. In the event that the speed rises as a result of a reduction in load, the governor mechanism will shut the supply valve to an extent that is adequate to bring the engine back down to its initial speed. As a result, the purpose of a governor is to regulate the variations in engine speed that are caused by shifts in the load.

The centrifugal governors look quite different from their inertia counterparts because the inertia governors are attached to an engine's crankshaft or flywheel. The balls are set up in such a way that the inertia force brought on by an angular acceleration or retardation of the shaft has a tendency to change their locations. This is because of the way the balls are placed. The amount of governor ball displacement is modified by the governor mechanism, which in turn affects the quantity of fuel that is supplied to the engine. This mechanism is regulated by proper springs. Inertia governors are more sensitive than centrifugal governors, yet balancing the revolving components of the governor may be exceedingly challenging. Because of this, centrifugal governors are employed in more applications than their linear counterparts. Only centrifugal governors will be covered in this article. At the very top of the spindle, there are two arms that are hinged together, and at the opposite ends of those arms, there are two rotating balls. The arms act as hinges on one end of each of the links, while the sleeve, which may slide over the spindle, acts as a hinge on the other end of each of the links. The speed of the crankshaft is conveyed to the spindle by way of a suitable system that utilizes a pair of bevel gears as the transmission mechanism. Therefore, the centrifugal force caused by the rotation of the spindle of the governor causes the weights to move away from the center of the mechanism. The result is that the sleeve moves in an upward direction as a result of this. This movement of the sleeve is transferred by the lever to the throttle valve, which then either partly shuts or opens the steam

pipe, reducing or increasing the amount of steam that is supplied to the engine so that the engine speed may be brought within the acceptable range.

A Porter governor is characterized by having two or more masses that are collectively referred to as the governor balls and that revolve around the axis of the governor shaft. The governor shaft is powered by the engine crankshaft through proper gearing. The arms are connected to the governor balls in some way. The lower arms are connected to the sleeve, which serves as a central weight and is located in the middle of the body. The governor balls will fly outward and the sleeve will move higher if the speed of the rotation of the balls rises as a result of a reduction in the load on the engine. This will result in the fuel channel being closed until the engine speed returns to its intended level. If the engine speed drops because of the increased load, the governor balls will fly inward and the sleeve will move downward, which will open the fuel passage more for oil until the engine speed returns to its designed speed. This process will continue until the engine speed returns to its designed speed. When the inward regulating force is just enough to keep the outward inertia or centrifugal force in check, we say that the engine is operating at the speed for which it was built.

The Porter governor was later modified to become the Proell governor. The governor's balls are held on an extension that is attached to the lower arms of the governor. When all other variables are held constant, such as the mass of the ball, the mass of the sleeve, and the height of the governor, a Proell governor has a lower maximum speed than a Porter governor. It's possible that a ball with a lower mass might be utilized in the Proell governor while still maintaining the same equilibrium speed.

The Hartnell governor is a spring loaded governor, which means that the governing force in this kind of governor is given a significant amount by the spring push. The Hartnell governor is an example of one of the available kinds. It is made up of a casing that is attached to the spindle. A spring that has been compressed is inserted into the casing, and this spring pushes against the top of the casing as well as against adjustable collars. The speed of the governor determines the amount of vertical movement that may occur on the vertical spindle by the sleeve. The governor balls are transported by a bell crank lever, which is pivotally attached to the bottom of the casing. The balls will fly outwards or inwards depending on the direction of the change in the speed of the governor shaft.

Poppet valves are often responsible for controlling both the intake and exhaust of internal combustion engines, with very few exceptions. Strong springs are responsible for keeping these valves in place on their seats. However, since valves typically open inward, the pressure within the cylinder also contributes to keeping them closed. The valves are dislodged from their seats, and the ports are opened, using either cams with a projecting section that are intended to produce the needed time of opening, or eccentrics that operate via linkage. The cam gear is the method that is used more frequently, but in either case, it is imperative that the valve gear shaft of an engine rotate only once from the beginning to the end of a complete cycle. This is the case regardless of the number of strokes that are required to finish the cycle. Cam gears are used more frequently than cam gears. This is vital to ensuring that the valve gear can be continuously regulated in accordance with the requirements. In order to do this, the camshafts and eccentrics of four-stroke engines are placed on shafts that are operated at a speed that is half that of the crankshaft via gearing. The speed of the engine and the intended rate of valve opening both play a role in determining the curves that are utilized for the active faces of the cams.

For a four-stroke engine, this component includes the poppet valve, the steam bushing or guide, the valve spring, the spring retainer, the lifter or push rod, the camshaft, and the half-speed gear. The poppet valve is widely utilized despite the fact that it generates a lot of noise and may be difficult to cool down. This is because of the poppet valve's ease of use and its capacity for efficient sealing regardless of the operating circumstances. The valve is put through a very taxing amount of work. It is located in the combustion chamber, where it is subjected to the high temperatures produced by the burning of gases, and the exhaust valve itself may reach a high temperature since there is no access to external cooling. Because of this, the exhaust valve is made out of special heat-resistant alloys, and it may sometimes have a hollow design that is filled with mineral salts in order to allow for heat dispersion. Both of these features are intended to reduce the amount of heat generated by the valve. When the valve is operating, the salts turn into a liquid, which allows them to transmit heat from the head to the stem. The heat is then transferred from the stem to the cylinder block through the stem guide.

It is extremely crucial to get the timing of the valves, which refers to when they open and close in relation to the movement of the piston, right if you want the engine to run as efficiently as possible. Drive for the camshaft may be provided either by gears or by a chain and sprocket arrangement (called a timing gear or timing chain). The exact timing of the valves would be thrown off if there was even the slightest amount of wear on the gears or the chain and sprocket. Therefore, it is preferable to steer clear of the use of several gears or lengthy chains in the driving system for the camshaft.

In theory, the valves are supposed to open and shut at the top dead center (TDC) or the bottom dead center (BDC), but in practice, they do so at some point either before or after the piston reaches the upper or lower limit of travel. There is a justification for this action. Consider, for instance, the intake valve on the device. On the exhaust stroke, it will often open up many degrees of crankshaft rotation before top dead center. This means that the intake valve starts opening before the exhaust stroke is completely over. This allows the valve to reach its completely open position before the intake stroke starts, which is an important safety feature. When the intake stroke begins, the intake valve will already be fully open, allowing the air-fuel combination to immediately begin entering the cylinder. This allows the engine to produce more power. After the piston has crossed B.D.C. at the conclusion of the intake stroke, the intake valve continues to stay open for quite a few degrees of crankshaft rotation. This occurs because the intake stroke is longer than the exhaust stroke. This gives the air-fuel combination more time to continue to flow into the cylinder, giving it more time overall. The transfer of air and fuel mixture into the cylinder is unaffected by the fact that the piston has already crossed B.D.C. and is going up or into the compression stroke while the intake valve is still open. In fact, the air-fuel combination continues to be drawn in even as the intake valve begins to shut.

This is because the air-fuel combination has inertia, which is the opposite of momentum. That is, when it has started flowing through the carburetor and into the engine cylinder, it makes an effort to continue flowing in the same direction. After then, the momentum of the mixture ensures that it continues to flow into the cylinder, despite the fact that the piston has begun to move on the compression stroke. This results in a greater power stroke as a consequence of the increased amount of air and fuel mixture that is packed into the cylinder. In other words, the volumetric efficiency is improved as a result of this.

On the power stroke, the exhaust valve opens well before the piston reaches B.D.C. for a reason that is somewhat analogous to the previous explanation. By the time the piston is close to B.D.C., the majority of the force that was pushing on the piston has been removed, and there is

no loss of power as a result of opening the exhaust valve near the end of the power stroke. Because of this, the exhaust gases have more time to begin exiting the cylinder, which ensures that the exhaust has gotten off to a good start by the time the piston has passed B.D.C. and begun the exhaust stroke. After the piston has passed top dead center and the intake stroke has begun, the exhaust valve will begin opening after a certain number of degrees of crankshaft rotation have passed. This makes efficient use of the momentum that is provided by the exhaust gases. They are moving quickly in the direction of the exhaust port, and the exhaust valve is being held open for a few degrees after the beginning of the intake stroke. This gives the exhaust gases some additional time to leave the cylinder before the intake stroke begins. This enables a greater quantity of the air-fuel mixture to be drawn in during the intake stroke, which ultimately results in a stronger power stroke. In other words, its volumetric efficiency is increased.

The actual timing of the valves varies from engine to engine that uses a four-stroke cycle. It is important to note that the inlet valve opens 15 degrees of crankshaft rotation before top dead center (TDC) on the exhaust stroke and continues to remain open until 50 degrees of crankshaft rotation after bottom dead center (BDC) on the compression stroke. On the power stroke, the exhaust valve opens 50 degrees before B.D.C., and it maintains its open position 15 degrees after T.D.C. on the inlet stroke. Because of this, there is a 30-degree overlap between the two valves at the end of the exhaust stroke and the beginning of the compression stroke.

1.1.5 Engines classification

Engines with internal combustion and reciprocating motion are common in a wide variety of economic fields, and they even dominate certain of these fields. The following is a summary of some of the primary classes of engines based on the applications they are used for. Although there is substantial overlap between the different classifications, the following descriptions should give you a general understanding of the breadth of uses for internal combustion engines.

Applications in utility and gardening, such as hedge clippers, edgers, and lawn mowers, are the greatest examples of small engines in action. The majority of the time, these engines are comprised of a single cylinder, which contributes to their lightweight design, low cost, and simplicity. In many of these applications, the design of the two-stroke cycle is used because it meets the criteria for having a cheap initial cost and a small weight. (The designs of a two-stroke cycle and a four-stroke cycle are discussed further below.) The next type of engine includes those that are often seen in motorcycles and scooters. These engines are likewise lightweight, but their price tag could be a bit higher. They might have more than one cylinder, and the majority of the time, their design will be based on a four-stroke cycle.

The level below is for vehicles considered light duty. The common automobile, pickup truck, and utility vehicle are all included in this category, as are several aircraft and helicopters. Engines in this market category range from small two-cylinder engines to massive eight-cylinder (or more) engines. This market segment is either the largest or one of the largest in size. Recent manufacturing trends have preferred smaller engines (for example, four-cylinder engines) for light-duty automotive applications. This preference may be attributed to a variety of different factors. These engines may be as simple as they get or they may have all the bells and whistles. In 2015, full-featured spark-ignition (gasoline) engines comprised components such as variable valve lift and timing, direct cylinder injection, and advanced electronic control systems. These full-featured engines can deliver high performance while also achieving high efficiency and low emissions.

The subsequent category would be one that included both on-road and off-road heavy-duty vehicles. This classification encompasses a wide variety of markets, including those for trucks, agricultural vehicles, military vehicles, and earth-moving vehicles, among others. For these applications, large diesel engines are almost always used because of their high efficiency, long life, and high torque. The next category would be for railroad locomotives, followed by intermediate vessels in the marine industry. Once again, large diesel engines comprising at least a dozen cylinders would be utilized in these applications.

The following category would be stationary engines, which are used primarily for the generation of electrical power. These engines could supply either continuous power, standby power, emergency power, or temporary power, depending on the situation. In larger situations, diesel engines are almost always used, even though there are many different kinds of engines that could be used. These engines almost often run at a steady speed, which is chosen so that it can perfectly fit the needs of the generator.

The world's most powerful reciprocating engines are often found on very big ships. Because the construction of these engines is more similar to that of a building than it is to that of an ordinary engine, they are also referred to as "cathedral engines". These diesel engines often have a two-stroke cycle and run at low speeds (less than 100 rpm). Additionally, the diesel fuel they use is typically of inferior quality. They are able to reach some of the greatest efficiencies known for reciprocating engines because of their massive size and low speed, which allows them to achieve some of the best efficiencies known for reciprocating engines.

As can be seen from the examples given above, internal combustion engines (IC engines) may be adapted to a diverse set of uses. So, the above examples show that the IC engine can be used in many different ways.

1.1.6 Components

The engine structure, which is typically composed of the engine block and the cylinder head, is one of the fundamental components of an internal combustion engine (ICE). The engine cylinders, pistons, crankshaft, camshaft (if it's housed in the block), and crank case are all included inside the engine block. In certain configurations, the fuel injectors are housed inside the cylinder head together with the spark plugs, overhead camshaft, valves, and other components. Stems, seats, and return springs are the three components that make up a valve system. The components that make up a piston are referred to as the piston, the rings, and the piston pin attachment. The piston and the crankshaft are connected to one another via connecting rods. If the camshaft is housed within the block, the valve actuation system will often include push rods as one of its components. Bearings, components for the water cooling system, gaskets, oil components, and fuel pumps are some of the other elements. Although these components are unique for each version of the engine, they often have some fundamental traits in common with one another.

1.2 HISTORICAL BACKGROUND

We briefly touch on a few of the key players in the invention and development of the internal combustion engine in this section. Today's engine designers are greatly inspired by the brilliance and imagination displayed by these early engineers in creating these remarkable inventions. J. Lenior (1822–1900), a Belgian engineer, created a two-stroke engine in 1858 that had an efficiency of about 5% and produced 6 horsepower. A spark ignited a gas-air combination that was sucked into the engine during the intake stroke and set it ablaze. This caused the cylinder pressure to rise during the second half of the stroke, which produced work. Through an exhaust valve, the return stroke was employed to eliminate the combustion byproducts. The stationary power applications of the Lenior engine were its main use [1].

George Brayton (1830–1892), an American mechanical engineer, developed and marketed the Brayton's Ready Engine, a constant pressure internal combustion engine, in 1872. Two reciprocating piston-driven cylinders, a compression cylinder and an expansion cylinder, were employed in the engine. Because the gas-air combination was started by a pilot flame and burnt at constant pressure as it was pumped from the compression cylinder to the expansion cylinder, this cycle was also known as the "flame cycle." The first automobile was powered by a Brayton piston engine in 1878. Gas turbines now use the Brayton cycle, a thermodynamic cycle that uses revolving fan blades to compress and expand the gas passing through the turbine [2].

The Otto Silent Engine, the first functional four-stroke engine with in-cylinder compression, was created in 1876 by German engineer Nikolaus Otto (1832–1891). The gas engine's 2.5 compression ratio resulted in 2 horsepower at 160 revolutions per minute and 14% braking efficiency. The internal combustion engine industry was started by Nikolaus Otto, who is credited with creating the modern internal combustion engine. A. de Rochas had developed and patented the idea of a four-stroke engine in 1861, but Otto is credited with being the first to construct and market a functional flame ignition engine. Otto was self-taught; he had no official engineering education. He spent his entire professional life working to enhance internal combustion engines [3]. He established the first internal combustion engine manufacturer, N. A. Otto and Cie, in 1872 and employed Gottlieb Daimler and Wilhelm Maybach, who later launched the Daimler Motor Company, the forerunner of the automobile industry, in 1890. The automobile business that is now known as BMW was started by Otto's son Gustav.

Scottish mechanical engineer Sir Dugald Clerk (1854–1922) developed and produced the first workable two-stroke engine in 1878. In 1881, Clerk, who had graduated from Yorkshire College, received a patent for his two-stroke engine. His career-long efforts to optimize the combustion processes in large-bore two-stroke engines have earned him recognition. The two cylinders in Clerk's engine were used to compress and transmit the intake air and fuel mixture from the pumping cylinder to the working cylinder, which produced power. Poppet valves were utilized for the intake flow, and the combustion gases were expelled through a cylinder port that was left open by the piston throughout the expansion stroke. Coal gas, a mixture of methane, hydrogen, carbon monoxide, and other gases created by the partial pyrolysis of coal, was the fuel source for many of these early internal combustion engines, including the Lenior, Brayton, and Otto engines. In the 1880s, crude oil refineries made enough gasoline and kerosene to make a market for internal combustion engines that ran on liquid fuel.

One of the pioneers in the automobile industry was the German engineer Gottlieb Daimler (1834–1900), who is known as one of the inventors of the industry. In 1883, he invented a high-speed, four-stroke engine that was water-cooled. The engine had a diameter of 70 mm and a

stroke of 100 mm, and it generated around 1 horsepower at 650 revolutions per minute. In a carburetor, the gasoline fuel is heated to the point of vaporization before being combined with the intake air. After that, it went via an intake valve that was loaded with a spring and actuated by sub-atmospheric cylinder pressure before entering the cylinder. A flame tube that was positioned just below the intake valve was responsible for lighting the fuel-air combination on fire. A cam lobe located on the flywheel was responsible for operating the exhaust valve. In 1886, Gottlieb Daimler constructed the first vehicle with four wheels, and in 1890, he established the Daimler Motor Company [5].

Karl Benz, a German engineer who lived from 1844 to 1929, was successful in developing a 3.5 horsepower liquid-fueled four-stroke engine with a carburetor and spark ignition in the year 1885. An electrical induction coil with a rotary breaker that was controlled by the engine was part of the ignition system. Additionally, a spark plug that could be removed from the cylinder head was part of the system. This kind of ignition system is comparable to what is present in modern engines. In the year 1886, an engine was fitted to a one-of-a-kind carriage that had three wheels and was dubbed the first "horseless carriage." The engine was linked to the rear axle by means of a two-chain system that functioned as the gearbox.

Rudolph Diesel, a German engineer who lived from 1858 until his death in 1913, invented the first functional four-stroke engine in 1897. Diesel's engine used direct injection of liquid fuel into the combustion chamber. The high compression ratio of the engine led to the fuel-air combination spontaneously igniting and burning, which was the desired outcome. After earning his degree in 1880 from Munich Polytechnic, Diesel collaborated with his old professor, Carl von Linde, first on ammonia Rankine cycle refrigeration and then with the MAN firm to develop compression ignition engines. Carl von Linde was one of Diesel's professors. When he was designing his engines, he tried to adhere as closely as possible to Carnot's thermodynamic principles. Accordingly, his first goal was to have combustion at a constant temperature; however, this was not attained in reality, and he chose the approach of having combustion at a constant pressure instead [6].

The single-cylinder engine used by Rudolph Diesel had a diameter of 250 mm and a stroke of 400 mm, which resulted in a displacement of 20 liters. Air injection was the method used to atomize the diesel fuel. This is a process in which compressed air is used to entrain diesel fuel in the injector and then carry it into the cylinder. When operating under full load, the engine turned at a speed of 170 revolutions per minute, generated 18 horsepower, and had an efficiency of 27%. This efficiency is far higher than that of the spark-ignition engines and steam engines that were used during that time period.

Sir Harry Ricardo (1885–1974) was a prominent English engineer and a graduate of Cambridge University's department of mechanical engineering. He received a patent for the use of a spherical prechamber called the Ricardo "Comet" to significantly increase the fuel-air mixing rate. This invention enabled diesel engines to be used in high-speed engine vehicular applications requiring 2,000 rpm or higher. During his career, Ricardo also contributed to a greater understanding of the role that turbulence, swirl, and squish play in enhancing flame speed in both spark and diesel engines. Additionally, he commercialized sleeve valves for aircraft engines, developed an octane rating system for quantifying knock in spark engines, and founded what is now known as the Ricardo Consulting Engineers Company [7].

Since early engines generated only a small amount of power, their cooling system consisted of air. Natural convection water cooling using the thermosyphon concept and forced convection

cooling using water pumps became standard for larger horsepower engines around 1910. Natural convection cooling uses thermosyphons. Both the Wright Brothers' Flyer engine from 1903 and Henry Ford's Model T engine from 1908 utilized water cooling that was facilitated by natural convection.

1924 was the year that saw the introduction of the very first multicylinder diesel engines for trucks. The Mercedes 260D, which was originally shown to the public in 1936, is recognized as the model that pioneered the diesel-powered automotive market. It was powered by a 2.6-liter, four-cylinder, prechamber diesel engine that generated 45 horsepower at 3000 revolutions per minute.

In the first half of the 20th century, the most common engine layouts for vehicles were four-stroke, water-cooled engines with either four or six in-line cylinders with side valves. A combustion chamber served as the housing for the valves, which were situated on the cylinder's side. At the current time, the overhead valve arrangement is by far the most common kind of engine configuration to be found in use.

1.3 COMMON ENGINE CYCLES

1.3.1 Spark-Ignition Engine

The steps in the functioning of a four-stroke spark-ignition engine are as depicted in Figure 9: Four-stroke spark-ignition engine functionality.

1. A fuel-air combination is sucked past the throttle and into the cylinder during the intake stroke, where it is ignited.
2. When the valves are closed during a compression stroke, the temperature of the combustion mixture increases. Near the conclusion of the compression stroke, a spark plug ignites the mixture.
3. The combustion of the fuel-air combination causes an expansion, also called a power stroke.
4. The burnt gases are released through the exhaust valve as a result of an exhaust stroke.

The engine's air supply is channeled by the intake manifold, a network of tubes that delivers a uniform air-and-fuel combination to each cylinder. Through the use of a fuel injector or carburetor located in the intake manifold, the intake port, or directly in the cylinder, the fuel (usually gasoline) is combined with the inlet air to create a consistent mixture that is then injected into the cylinder. When a spark ignites the mixture, a turbulent flame starts and spreads throughout the mixture, increasing the temperature and pressure within the cylinder. When the flame reaches the cylinder's walls, it is put out. It is called a "knock when the compressed gases in front of the flame autoignite due to excessive initial pressure. The efficiency of spark-ignition engines is capped by the maximum compression ratio because of knock. The exhaust manifold is the pathway for the burnt gases to leave the engine. The exhaust manifold collects the exhaust gases from each cylinder and directs them to one large exhaust stack.

The amount of air introduced into the spark-ignition cycle is adjusted via a throttle. When the throttle is closed, less air can go into the cylinder, resulting in a corresponding drop in pressure.

Because the fuel rate is proportional to the air rate, the throttle in a spark-ignition engine is the real power regulator.

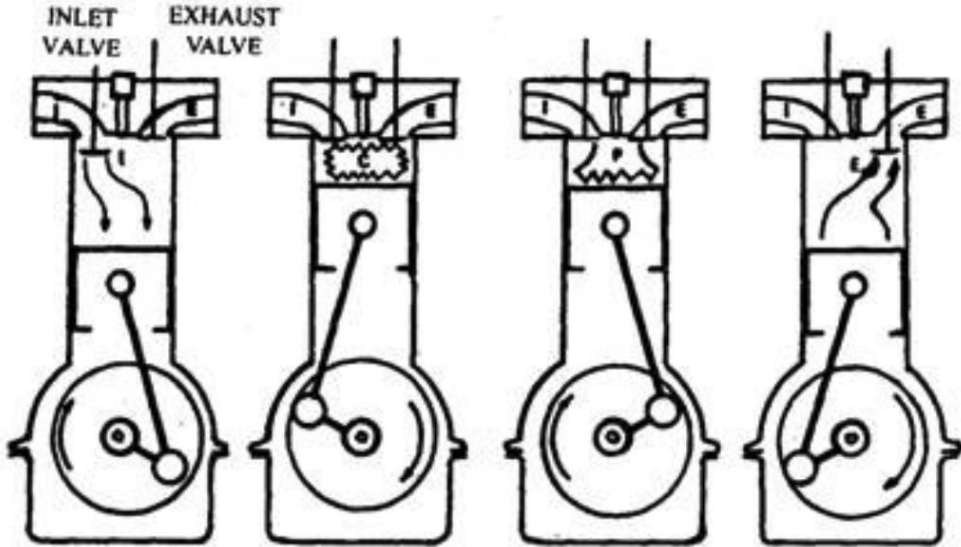
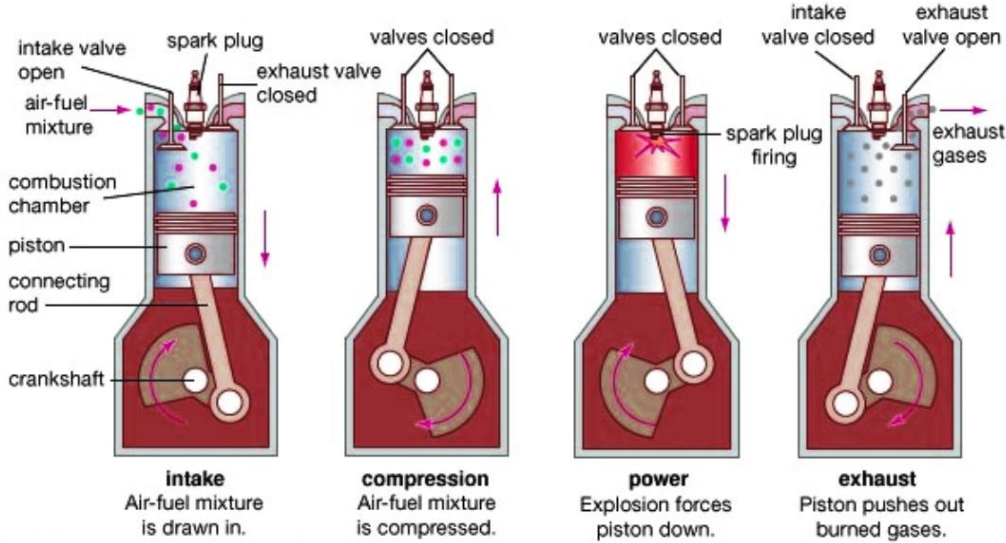

Figure 9:Four-stroke spark-ignition engine functionality [8]

1.3.2 Compression Ignition Engine

The following is the order of events for a four-stroke compression ignition engine:

1. During the intake stroke, air is sucked into the cylinder via the intake valve.
2. The air temperature is increased during a compression stroke to a point where the fuel can ignite spontaneously. Before the piston returns to the top of the compression stroke, diesel fuel is sprayed into the cylinder.
3. Later in the compression stroke and the expansion stroke, the diesel fuel evaporates, mixes, ignites, and burns.
4. The burnt gases are released outside of the engine via an exhaust stroke that opens the exhaust valve.

Diesel engines have unrestricted air intake and burn lean. How much fuel is injected and how much fuel spray is mixed with the inlet air determine how much power is produced. It's important to note that the injection time varies in relation to the workload of the engine. Diesel engines typically have a compression ratio between 15 and 20, higher than that of spark-ignition (SI) engines, which is necessary to ignite the fuel-air combination and results in better theoretical efficiency. Knock limitation in SI engines is substantially diminished due to the timing of the diesel fuel's introduction to the cylinder air.

Diesel engines can only function to a certain extent before the fuel and air have had enough time to mix; otherwise, the engine would produce less power, more unburned hydrocarbon emissions, and more visible smoke due to the fuel and air not being well combined. Many variants of the diesel combustion chamber have been developed to provide sufficient mixing, as we shall see. Two common methods of igniting diesel fuel are direct injection (DI) into the cylinder and indirect injection (IDI) into a prechamber attached to the cylinder. When the engine's working range is limited, as it often is in marine, locomotive, and electrical power production applications, direct injection engines tend to prevail. Vehicles that require an engine to operate efficiently over a wide range of speeds and loads often employ indirect injection engines.

By compressing air into a prechamber during the compression stroke, high mixing rates are achieved when diesel fuel is sprayed into the prechamber at the conclusion of the compression stroke through indirect injection. To start a fire, the prechamber is heated to a higher temperature and pressure than the main chamber. This causes the combusting combination of burning gases, fuel, and air to be sucked back into the main chamber, where it spreads as a very turbulent whirling flame.

Diesel engines fall into one of three categories based on their maximum speed since the mixing time decreases with increasing engine speed. High-speed diesel engines use premium distillate fuels, can have a bore size of up to 300 mm, and are designed to run at speeds of 1000 rpm or more. The rpm range for medium-speed diesels is between 375 and 1000, the bore size is medium (usually between 200 and 600 mm), and they can run on a variety of fuels. Low-speed diesel engines use residual fuel oil, have a large diameter (> 600 mm), and rotate at rates lower than 375 rpm. The fact that different engine manufacturers have come up with designs that are

optimal for different uses exemplifies how heavily the optimal design depends on the individual use.

1.3.3 Two-Stroke Engine

A cycle in a two-stroke engine consists of a single revolution of the piston, as suggested by the name. In contrast to four-stroke engines, which only have a power stroke once every two revolutions, two-stroke engines have a power stroke every time the engine turns. Two-stroke engines are easier to maintain mechanically and have a greater specific power (the ratio of power to weight) than four-stroke engines. Either a spark or a compression cycle is used to ignite the fuel. The scavenging process, which involves simultaneously draining the burned mixture and injecting the fresh fuel-air combination into the cylinder, is one reason why two-stroke engines aren't as powerful as four-stroke engines. As we will see, many variants of two-stroke engines have been developed to provide sufficient exhaust gas recirculation (Figure 10: Two-Stroke engine).

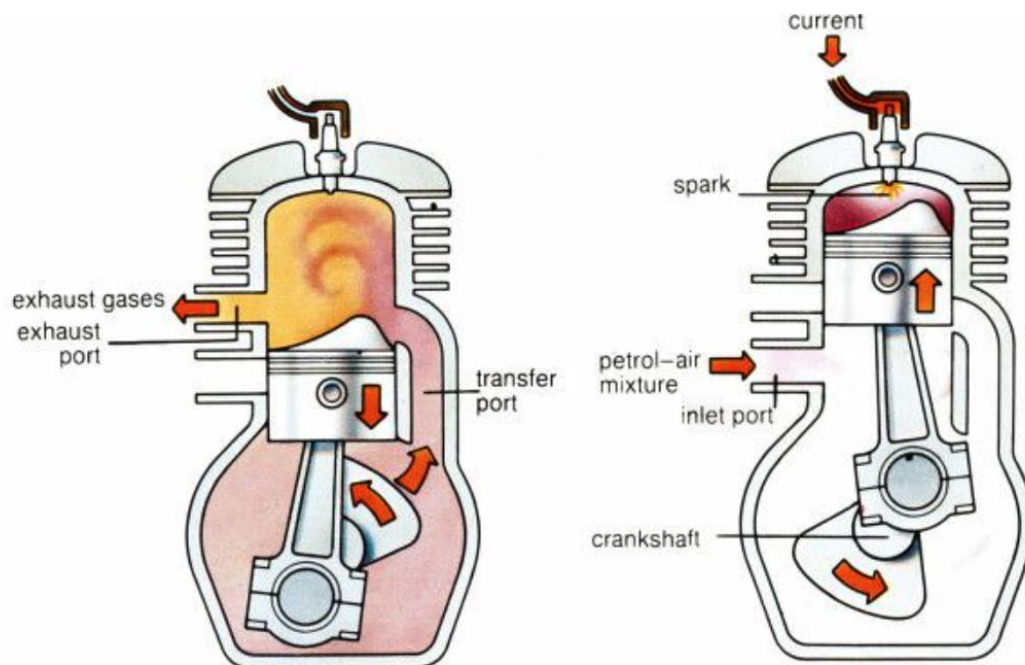

Figure 10: Two-Stroke engine [8]

Subatmospheric pressure is generated in the crankcase during compression of the scavenged two-stroke cycle. This releases a reed valve, which, in the scenario shown, allows air to flow into the crankcase. At the point when combustion's expansion phase begins, the air in the crankcase pushes the reed valve shut, compressing the air within. The cylinder pressure rapidly drops to atmospheric levels when the piston pushes open the exhaust ports and exhaust gases begin to escape. When the intake valves are opened, the compressed air from the crankcase is sucked into the cylinder, where it mixes with the exhaust gases and forces them out. Scavenging is the process by which fresh air pushes out stale air.

Because of this imperfect scavenging, part of the air will bypass the intake and exit the engine through the exhaust port, a phenomenon known as short-circuiting. Exhaust gases will likewise mix with some of the air, and the remaining entering air will force some of this mingled gas

out. The severity of the issue varies considerably depending on port configurations and piston crown shapes.

Carbureted gasoline engines are especially vulnerable to poor scavenging since the crankcase contains a fuel-air mixture instead of air. A portion of this fuel-air combination will be released in the exhaust, leading to fuel waste and an increase in hydrocarbon emissions. Whenever fuel economy is secondary to other considerations and the engine's inherent simplicity can be put to good use, carbureted two-stroke motors are a viable option due to their inexpensive price and high power-to-weight ratio. Motorcycles, chainsaws, boat motors, and model airplane engines are just a few common examples. However, due to their poor emission characteristics, motorcycles are seeing a decline in popularity. The majority of two-stroke industrial engines run on diesel, and those that do are usually supercharged. Scavenging in a two-stroke diesel or fuel-injected gasoline engine is accomplished solely using air, so fuel is not wasted in the event of a short circuit or when it mixes with the exhaust gases.

1.4 IDEAL CYCLES FOR GAS ENGINES

The study of ideal gas engine cycles as simplified models of internal combustion engine operations is extremely beneficial for highlighting the main aspects determining engine performance. In an ideal gas engine cycle analysis, the burning process is seen as adding the same amount of energy to an ideal gas. The study is simplified by describing the combustion process as an energy addition because the specifics of combustion physics and chemistry are not necessary. The different combustion processes are either treated as processes with constant volume, constant pressure, or finite energy release.

The internal combustion engine is not a heat engine since it produces work through internal combustion processes, and it is an open system with the working fluid flowing through the cylinder. Gas engine models, on the other hand, are beneficial for introducing cycle characteristics that are also utilized in more complicated combustion cycle models, notably the fuel-air cycle. The fuel-air cycle accounts for the composition change of the fuel-air mixture during combustion.

This chapter also covers closed-system and open-system thermodynamics. The compression and expansion strokes are modeled using a first-law closed-system analysis, while the intake and exhaust strokes are modeled using an open-system control volume analysis. The residual percentage of combustion gas, f , remaining in the cylinder at the end of the exhaust stroke is an essential metric in the open-system analysis.

To simplify the calculations, let us suppose that the gas cycles examined in this chapter are represented using an ideal gas with a constant specific heat ratio and gas constant R . This assumption leads to straightforward mathematical equations for efficiency as a function of compression ratio. For calculating the gas cycle of an internal combustion engine, the value of γ is usually between 1.2 and 1.4, and the value of the gas constant R is usually between 0.28 and 0.31 kJ/kg-K. At a compression temperature of 650 K, an unburned stoichiometric isooctane/air combination has $\gamma = 1.31$ and $R = 0.28$ kJ/kg-K, while after combustion at an expansion temperature of 2250 K, the equilibrium combustion product mixture has $\gamma = 1.19$ and $R = 0.30$ kJ/kg-K.

Sadi Carnot (1796–1832), a French engineer, created the scientific theory of heat engine cycles in 1824. His hypothesis is based on two basic principles. The first axiom states that in order to

employ a flow of energy to create power, two bodies at different temperatures—a hot body and a cool body—must exist. Work is created by transferring energy from a heated body to a cool body or reservoir. The second axiom is that there must never be a wasteful flow of energy; hence, heat transfer at a constant temperature is required. Carnot created an ideal heat engine cycle that is reversible, meaning that if the pressure balance is changed, the cycle of operation is reversed. The efficiency of this cycle, known as the Carnot cycle, is solely determined by reservoir temperatures, and it increases as the temperature of the high temperature reservoir rises. Because it is reversible, the Carnot cycle is the most efficient, and it is the benchmark against which all practical engines are measured.

1.5 ENGINE CONFIGURATIONS

There are a wide variety of designs for internal combustion engines. Piston-cylinder geometry, intake and exhaust valve geometry, supercharger or turbocharger use, fuel delivery system, and cooling system are all distinguishing features of any engine design, whether it runs on a four-stroke Otto cycle or a two-stroke Diesel cycle. Even today, the most common type of internal combustion engine uses a piston and cylinder that move in opposite directions to generate power.

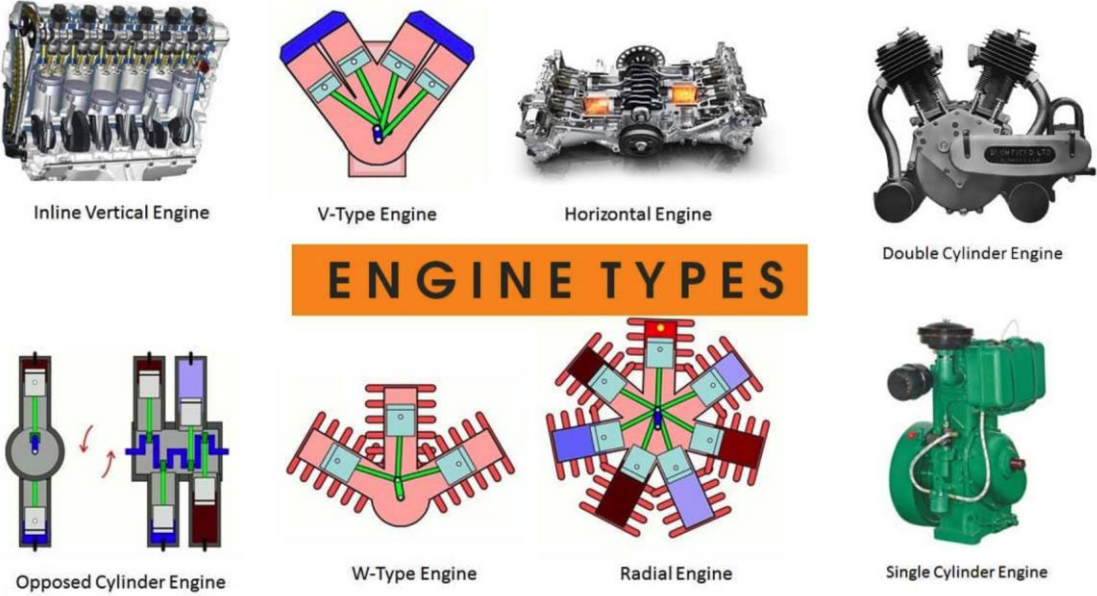

Figure 11: Different engine types [10]

Different piston-cylinder shapes have been developed since the advent of the internal combustion engine, as seen in *Figure 3*. Multiple criteria and limitations, such as engine balance and available space, influence the decision to choose any particular configuration. The in-line engine's ease of production and upkeep has made it the industry standard. The V-shaped engine's shape is achieved by having two parallel banks of cylinders placed at an angle to one another. A V engine with piston banks offset by 180 degrees is a horizontally opposed engine. The W engine resembles the letter W and is made up of three parallel banks of cylinders that are angled with respect to one another. All of a radial engine's cylinders are in a single plane, and their axes are evenly spaced. Because all of the cylinders of a radial engine may be cooled by the air intake at the same rate, they are utilized in air-cooled aircraft. A master connecting

rod is utilized for one cylinder, and articulated rods are joined to the master rod since the cylinders are in a plane. The reciprocating piston-cylinder system isn't the only one available; the rotary Wankel engine, for example, uses a rotor with a triangle cross section that spins eccentrically inside a housing to accomplish the same goals of compressing, igniting, and expanding a fuel-air combination.

1.6 VALVE CONFIGURATION FOR INTAKE AND EXHAUST SYSTEMS

Valves that open and close at the appropriate moments, or ports that are exposed or covered by the piston, allow gas to enter and exit the cylinders. Intake and exhaust valves can be placed in a variety of locations and have a number of different configurations. Because of their superior sealing properties, poppet valves (Figure 4) are widely utilized in internal combustion engines. Although sleeve and rotary valves have seen application, they do not provide the same level of combustion chamber sealing as poppet valves.

Because of differences in airflow, cooling, and production, poppet valves can be installed either in the engine block or the cylinder head. Inlet and exhaust valves of under-head or L-head engines are arranged in the block parallel to the cylinders; this design is typical of older engines and smaller four-stroke engines. While undersquare (bore stroke) engines benefit from this setup because the valves are cooled by the same coolant used to cool the rest of the engine, the reduced volumetric efficiency is a result of the smaller valve diameters required. In the F-head layout, the intake valve is in the cylinder head above the cylinder, which makes the use of volume more efficient. The exhaust valve, on the other hand, is still on the side of the head.

Overhead or I-head valve placement is currently the norm for engines since it permits larger valves and hence better intake and exhaust flow. On the other hand, overhead valves are trickier to cool than L-head valves.

A four-stroke engine's camshaft spins at a rate equal to half the engine's rotational speed, allowing it to precisely manage the timing of the engine's valves. Camshaft lobes work in conjunction with lifters, pushrods, rocker arms, and other components to regulate valve movement. In early engines (about 1910), the pressure differential between the atmosphere and the cylinder opened the spring-loaded intake valves during the inlet stroke. Most modern car engines no longer have pushrods. Instead, they have overhead camshafts. This makes the valve train smaller and more reliable.

The timing profile of a set of valves varies. Because of fluid movement, the opening and closing angles of a valve are not always symmetric at its top and bottom dead centers. The use of sophisticated camshafts with movable lobes or motorized valves allows the timing of the valves to be adjusted to optimize volumetric efficiency. The valve opening time and length can be changed to improve power output and/or efficiency in response to variations in load and speed.

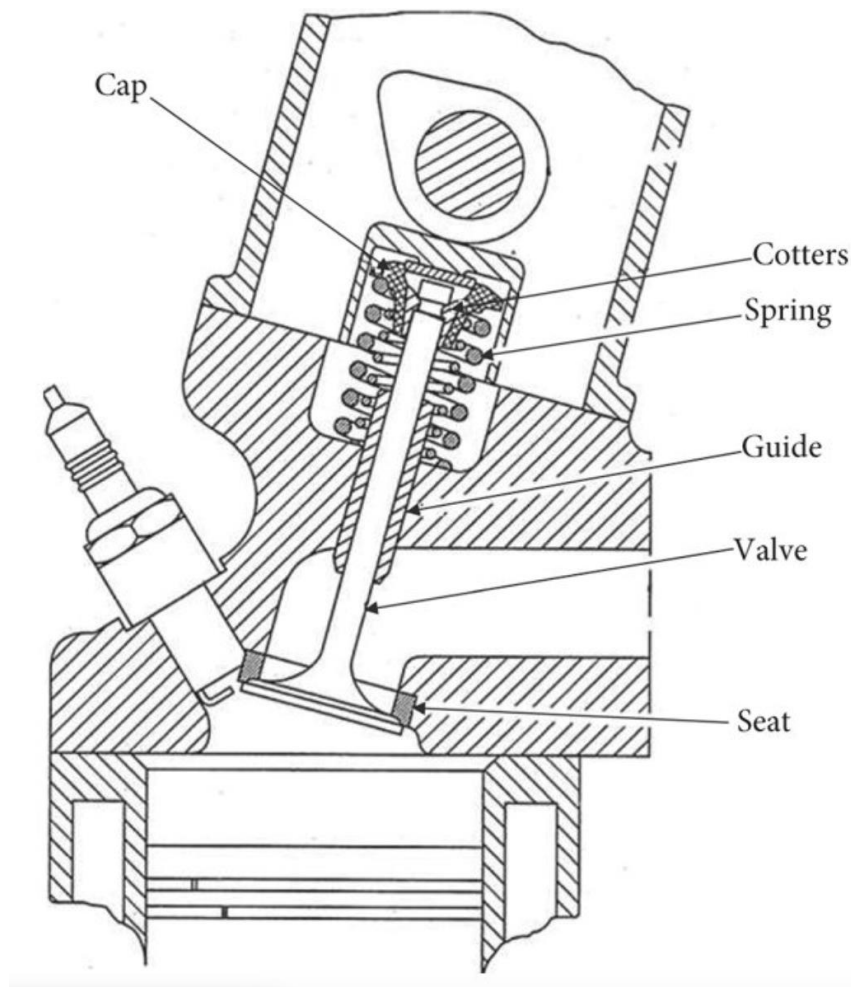

Figure 12: Poppet valve

1.7 SUPER AND TURBO CHARGERS

All the engines we've spoken about so far are naturally aspirated, meaning that the piston's downward action draws in air. The power of an engine can be increased by adding a supercharger or turbocharger. By using a compressor driven by the crankshaft, incoming air is compressed to a pressure greater than that of the ordinary atmosphere during the supercharging process. Compressing the intake air makes it more dense, allowing more fuel and air to enter the cylinder and produce greater power. A turbine operates a compressor, which in turn further expands the exhaust gas leaving an engine. The engine becomes more efficient as a result of recovering energy from the exhaust gas, and smaller engines may be built to provide the same amount of power thanks to the increased efficiency and the higher density of the incoming charge. Since the boost (density increase) produced by turbocharging is a nonlinear function of engine speed, it is minimal at low speeds and maximized at high speeds. Also, it's weak when the throttle is barely open and strong when it's fully engaged. These are very desirable qualities in a car engine, as they reduce energy waste caused by throttling or pumping. Turbocharging is a common feature in diesel engines of all sizes, but especially those powering trucks and SUVs. Superchargers that are driven by electricity and used in conjunction with a turbocharger to mitigate "turbo lag" will become more commonplace as 48V electrical systems become standard in automobiles.

1.8 CARBUTERED ENGINES AND FUEL INJECTION SYSTEM

The engine control and fuel distribution systems have seen revolutionary modifications in the recent years, and this trend is expected to continue. Computers now regulate the engine's ignition and fuel injection systems. In the 1980s, throttle body fuel injectors replaced carburetors in cars, and by the 1990s, port fuel injectors had taken their place. The fuel injectors for each cylinder are called port fuel injectors, and they are situated in the intake port of the cylinder right forward of the intake valve. Since the delay in fuel delivery from a port injector is substantially smaller than that from a throttle body injector, it is not necessary for the port injector to provide a constant fuel spray.

Many current production engines include spark-ignition direct injection. Fuel is injected directly into the cylinder at the end of the compression stroke with direct injection. Since the combustion knock limits are lessened in direct injection engines, their theoretical efficiency improves when compared to those using port injection. By removing the throttle, their volumetric efficiency improves at low loads. Charge cooling caused by the evaporation of the injected fuel in the combustion chamber improves volumetric efficiency.

1.9 SYSTEMS FOR COOLING

Roughly 30 percent of the fuel's energy is lost as waste heat, so some kind of cooling device is needed to get rid of it. The two most common methods of cooling are liquid and air. In most cases, a single loop of liquid cooling is used, with a water pump circulating coolant from the radiator to the engine block and finally to the cylinder head. The gasoline is vaporized with the help of a heated coolant that runs through the intake manifold. After rejecting the heat to the atmosphere through a radiator or heat exchanger, the coolant will return to the pump. A thermostat prevents coolant from recirculating to the radiator while the engine is cold, allowing it to heat up more quickly. While liquid-cooled engines are more peaceful than their air-cooled counterparts, they are prone to issues such as leakage, boiling, and freezing. Most engines with a power output of less than 20 kW are cooled by air. Fins are used in air-cooling systems to bring down the surface temperature of the air side. A combination of water and air to chill has been used in the past. An early 1920s car called the Mors used a combination of air and water cooling for its cylinders and their finned covers.

1.10 THERMODYNAMIC PROPERTIES

It's been established that a more accurate thermodynamic model than ideal gas models is necessary for comprehending internal combustion engines. In this chapter, we'll look at the thermodynamic characteristics of fuel-air mixtures and build models that may be used in internal combustion engines. Models for the characteristics of mixtures of ideal gases are discussed first, then kinetic models are presented, and finally stoichiometry and mole fraction analysis are discussed. Using data on pressure, temperature, and mole fractions of the various species present in fuel-air residual gas mixtures and combustion products, we will derive equations for the thermodynamic parameters of these systems.

Let's talk about the ambiance for a second. Depending on latitude, elevation, and time, air has different characteristics. For the purposes of this discussion, let's say that air is composed of

21% oxygen and 79% nitrogen by volume, or that there are 3.76 moles of nitrogen for every mole of oxygen.

CHAPTER 2: DIAGNOSTICS AND ENGINE MANAGEMENT

2.1 IN GENERAL

An internal combustion engine's electronic engine control unit (ECU) is responsible for controlling, optimizing, and supervising all of the important components and operations of the engine (ICE). At first look, this entails the following:

- the development of torque in accordance with the driver's accelerator pedal
- low fuel consumption
- low levels of exhaust pollutants and low levels of noise (as required by regulation)
- safe and responsible driving conduct

When it comes to the overall construction of internal combustion engines, the control functions can be assigned to a variety of different engine subsystems or engine elements, including the following:

- The air intake system
- The fuel injection system
- The fuel delivery system
- Combustion and the drive of the crankshaft
- Lubrication
- The mechanism for the exhaust gases
- A technique for cooling the air

A portion of the subsystems are fundamentally controlled mechanically, such as the timing and lift of the inlet and outlet valves for four-stroke engines via the camshaft; the fuel pressure and oil pressure via overpressure relief valves; and the coolant temperature via thermostatic expansion valves. Electronic control is used for a great deal of other significant factors, including air flow, fuel flow, combustion, torque, speed, and the treatment of exhaust gas. In the case of variable valve trains (VVT), however, the camshaft can also be regulated electronically. Additionally, the fuel pressure and oil pressure can also be adjusted electronically in common rail direct injection systems. As a result, electronically controlled actuators that work with electrical, pneumatic, or hydraulic auxiliary energy are necessary, in addition to sensors located within the engine that produce electrical outputs.

The improvement of the thermodynamic, fluid dynamic, and mechanical design and construction of internal combustion engines has led to a rising number of actuators and sensors, as well as a significant growth in the number of functions controlled by electronic control systems. Start, idling, warm-up, and regular operation are all under the direct direction of the electronic control unit (ECU). The magnitude of the programs and data stored in the digital microcomputer-based system is indicative of the expansion of the control functions. Within the past 15 years, the clock frequency of microprocessors has increased from 12 to 150 MHz, the databus width has increased from 8 bits to 32 bits, program storage has increased from 32 Kbytes to 5 Mbytes, the computing time has increased from approximately 10 to 300 millions instructions per second (MIPS), and the calibration labels have increased from approximately

2500 to 30000 (approximate numbers; see Section 5.1 for more information). Memory has risen by a factor of 1:100, computer power (measured in MIPS) has climbed by a factor of 1:30, and calibration parameters have increased by a factor of 1:10, all within this 15-year time span.

This progression was primarily driven by an increase in the number of variables that might be used to optimize the combustion process and the treatment of exhaust gas. For gasoline engines, this was first reflected in the optimization of valve timing and lift in combination with the injections, depending on load, homogeneous or stratified operation, and control. One example of this would be if the valve timing and lift were optimized in combination with the injections. In the case of diesel engines, this led to the optimization of multiple injectors, valve timing, turbocharging, exhaust gas recirculation, and particle filters and their respective regeneration cycles.

A complicated nonlinear multiple-input multiple-output system is the result of the engine control system having to be developed for 6–8 major controlled variables and 5–8 measured output variables. Some of the engine's output variables are controlled by feed-forward structures, which are also known as open-loop structures. This is due to the fact that several output variables, such as torque and some emissions, cannot be measured in mass-produced vehicles due to the fact that the necessary equipment is either too expensive or may not be reliable enough. In order to accomplish this, it is necessary to measure the position of the driver's pedals, as well as several variables that can have an effect, such as the speed of the engine, the air mass flow, the air temperature and pressure, as well as the temperature of the oil and coolant. Additionally, it is necessary to specify the feed-forward control actions that should be performed on the main variables that are being manipulated. When it comes to gasoline engines, feedback control, also known as closed-loop control, is utilized for both knock control and timing control. Idling speed and the temperature of the coolant fluid are both controlled through feedback on both types of engines. The feedforward structures have the benefit of not having any stability issues, but in order for them to function well, they require relatively accurate engine models as well as sensors for the primary affecting variables. The closed-loop structures adjust for measurable disturbances as well as those that are not recorded, but their controllers need to be accurately and robustly tailored to the nonlinear dynamic behavior of the engines. All of the control functions have a high dependence on the load, the speed, and the operating state, which can range from the beginning phase to the warm-up state to the normal state to the idling state to the overrun state to the shut-down state.

2.2 MANAGEMENT OF GASOLINE ENGINES

In order for gasoline engines to produce a particular amount of torque at the crankshaft, the air-fuel combination must be precisely calibrated. They need an almost stoichiometric combination of air and fuel in the range of 0.8–1.4 for ideal combustion, and because the three-way catalyst is most commonly used, the air/fuel ratio has to be precisely in the range of 0.98–1.02. Because of this, a throttle valve is typically used to restrict the flow of air during part-load operation. As a result, the cylinders draw air from the manifold at a pressure lower than atmospheric pressure. The amount of torque that is produced is determined, along with the fuel, by the air mass (air charge) that is drawn into the cylinders. It is either directly measured by a sensor that measures air mass or indirectly calculated by a sensor that measures pressure in the manifold. On the other hand, in contrast to diesel engines, gasoline engines suffer from charging losses when using the typical method of controlling the engine's load, which involves an upstream throttle. In response to the location of the driver's accelerator pedal, the electronic control unit (ECU)

sends orders to the electrically operated throttle valve, which in turn controls the amount of gasoline that is injected via the fuel injection system via feedforward control. In port injection, the fuel is injected into the intake manifold upstream of the inlet valves using a low-pressure pump that has a pressure range of 4–6 bars. In direct injection, high-pressure fuel pumps (120–200 bar) send the gasoline straight into the combustion chamber.

For a traditional kind of homogeneous combustion, the fuel is injected into the intake manifold during the induction stroke of the cylinders. This type of injection, known as "multi-point injection", can consist of many injection pulses at different points. The location of the accelerator pedal is translated by the ECU into a determined torque value that corresponds to the driver's preferences. The air charge and the corresponding fuel injection mass per cylinder, as well as an optimal ignition angle relative to the top dead center of the crankshaft, are calculated by using a variety of correction functions. The angle of the throttle valve, the angle of the fuel injection, and the duration of the injection, as well as the activation of the ignition coil, are set by feedforward control look-up tables. In order to achieve stoichiometric combustion for the most efficient conversion of CO, HC, and NO_x in the three-way catalyst, the amount of the injected fuel is adjusted by a cascaded lambda feedback controller using measurements in the exhaust system before and after the catalyst.

The direct injection in the cylinders has as an extra manipulation the high pressure in the fuel rail, and it enables a variety of combustion processes to take place. When the engine speed and torque are lowered, it is possible to get a stratified cylinder charge. This occurs when a cloud of flammable air and fuel mixture is produced in one zone of the cylinder and then transmitted to the spark plug. The opposite zone has surplus air and exhaust gases that haven't been completely burned off. A turbulence flap located in the manifold is responsible for controlling the zones. As a consequence, the throttle valve may be opened, which results in the elimination of throttling and charging losses, ultimately leading to improved efficiency. During the compression process, the fuel is injected. On the other hand, lean combustion results in higher NO_x concentrations, and a three-way catalyst cannot be employed since there is an excess of air in the system. Because of this, NO_x is cut down by the use of exhaust gas recirculation (EGR), which is controlled by an EGR-valve, and a NO_x accumulator-type catalytic converter is implemented. When operating at high speeds and torque, the engine is forced to operate in a homogenous mode since it is not possible to generate stratified conditions under these conditions. This two-mode combustion, which may also work in a three-mode configuration, necessitates the use of precise control functions for a number of variables, and it is carried out with the assistance of universal (broadband) lambda sensors that have changeable setpoints for the air-to-fuel ratio. A NO_x sensor might also be utilized in this process. In addition, knock feedback control adjusts the ignition angle by employing one or two knock sensors located in the crankcase. This action is taken to avoid knocking combustion, which can result in damage to the engine.

The phrase "electronic engine management" is commonly used as a shorthand way to refer to the comprehensive features that make up the engine control system. The individual feedforward and feedback control functions illustrate a hierarchical structure by consisting of higher-level control functions and lower-level control functions. This structure is displayed by the functions. Control subsystems or modules can be used to organize higher-level control operations such as torque control, injection and air/fuel control, ignition control, knock control, air charging, and EGR control. For instance, the position control of actuators and the low fuel pressure control are both examples of sub-level control tasks. These actuators are responsible for controlling the air flow, injection mass and angle, rail pressure, ignition timing, camshaft

phase, and recirculated exhaust gas flow. A cold start, the warming-up period, regular operation, idling, and shut-off are all examples of varied operating circumstances that might result in different control functions being used.

Automatic transmissions that use torque converters and planetary gears or double-clutch transmissions that use spur gears typically include a specialized electronic control unit that is mounted to the casing of the transmission. This device is responsible for controlling the transmission. The speed of the engine is determined together with the load that is drawing power, which in this case is the transmission and the car.

2.3 MANAGEMENT OF DIESEL ENGINES

If there are no turbochargers present and the torque is controlled by the amount of fuel mass that is injected, then the air that is drawn into the cylinders of diesel engines has a pressure that is somewhat lower than atmospheric pressure. The majority of modern diesel engines, on the other hand, come equipped with turbochargers to boost both their torque and their power. After then, the air charge is dependent on the charging pressure, also known as the boost pressure, which is regulated by the charging pressure controller. For example, the position of the wastegate or the position of a variable geometry turbocharger may be changed to alter the boost pressure (VGT). The diesel engine works with a significant amount of extra air when the load on the engine is low. This means that the air-to-fuel ratio, which is indicated by the excess air factor, is also considerable. Only when the load is very great does it approach 1 more closely. If it is reduced to an insufficient level, the diesel engine will begin to smoke. When compared to gasoline engines, diesel engines have a higher efficiency, particularly when operating at part load, because of the relatively high compression ratio in the cylinders, the low charging losses that result from an inactive throttle valve in the intake, and the good air supply that results from this combination. However, the oxidation of nitrogen gas found in the air results in the production of more NO_x gases the higher the combustion temperature is, and, as a result, the higher the thermodynamic efficiency is. In order to reduce the temperature of the combustion process and the amount of NO_x produced, it is possible to recycle the exhaust gases back into the intake, but this will have a negative impact on the fuel economy.

These days, most modern diesel engines use either a common rail or a unit pump injection system, both of which can reach pressures of up to 2200 bar. The Electronic Control Unit (ECU) sends orders to inject a certain quantity of gasoline into the cylinders based on the location of the accelerator pedal. Multiple injections, including pre-, main-, and after-injection pulses, are used so that the burning process may be influenced with regard to the optimum consumption of fuel, the generation of NO_x and soot, and the amount of noise that is produced. The EGR valve has a controlling influence, although an indirect one, over the air mass flow rate in the intake system (mainly in passenger car diesels). The Electronic Control Unit (ECU) sends orders to inject a certain quantity of gasoline into the cylinders based on the location of the accelerator pedal. Multiple injections, including pre-, main-, and after-injection pulses, are used so that the burning process may be influenced with regard to the optimum consumption of fuel, the generation of NO_x and soot, and the amount of noise that is produced. The EGR valve has a controlling influence, although an indirect one, over the air mass flow rate in the intake system (mainly in passenger car diesels). An increase in the flow rate of EGR results in a decrease in the flow rate of air. This is because the fresh gas mixture that is taken in by the cylinders remains almost the same at a certain operating point. This indicates that the ratio of m_{egr} to m_{air} will change. The observed mass flow rate serves as the control variable for the closed air mass

control loop. The reference value for this variable is derived from the intended reference surplus air factor, which is denoted by the symbol λ_{ref} . A further kind of feedback control is the charging pressure control loop, which operates either a wastegate in the case of turbochargers with fixed geometry or the guiding vanes in the case of turbochargers with variable geometry (VGT). Both closed control loops have a tight connection to one another.

Diesel engines need a speed controller for the maximum speed in order to restrict the speed by lowering the fuel quantity. This allows the engine to operate at a more manageable level. If you don't slow down, you risk damaging the engine by going too fast. This is due to the absence of load control, which is achieved by intake throttling. Idling also utilizes speed control, although not during the usual working range of diesel engines used in automobiles because this is not where they should be used.

The exhaust after-treatment is responsible for lowering levels of HC, CO, NO_x, and particles in the exhaust. An oxidation catalyst is often used to remove HC, CO, and some soot from the diesel engines used in passenger cars. It is possible that this step will be followed by a NO_x storage catalyst (NSC), which is characterized by a loading phase in which NO₂ is stored in a lean exhaust gas ($\lambda > 1$) during 30 to 300 seconds. Within two to ten seconds, the regeneration and elimination of NO₂ take place in an exhaust gas that is hot. By retarding the injection angle and throttling the intake air, this removal or decrease of NO₂ may be accomplished using CO and H₂ in a rich exhaust gas. The NO₂ can then be burned off. To properly regulate the storage catalyst, a temperature sensor and either a NO_x-sensor or a λ -sensor are required. Ammonia NH₃, which originates from liquid urea, is used in selective catalytic reduction (SCR), which is an alternative method for removing nitrogen oxides. This process runs continuously by injecting a urea/water solution ("add blue") from an additional tank. It is feedback regulated by employing NO_x- and NH₃-sensors to monitor the concentration of NO_x and NH₃.

Diesel particulate filters (DPF) have the ability to remove soot particles that have been emitted. They are made of porous ceramics or sintered metal and must be produced by the combustion of soot with the oxygen in the exhaust gas at a temperature of at least 600 degrees Celsius, which results in the production of carbon dioxide (CO₂). When a threshold that is based on a combination of differential pressure rise and predicted soot storage from a storage model is met, the regeneration process will begin. This criterion is what triggers the regeneration process. Then, depending on the condition in which the engine is functioning, the exhaust temperature is boosted using either a delayed main injection or an additional late injection in conjunction with intake air throttling. This regeneration takes around ten to twenty minutes, and the engine is managed in such a way that the torque does not noticeably decrease during this time. Both a differential pressure sensor and a temperature sensor are necessary for the regulation of the DPF.

As the control system for gasoline engines, it is arranged in a hierarchical structure that is separated into higher-level and lower-level control functions. In addition, it has a number of subcomponents that work together to regulate the engine. Torque control, injection and fuel control, air charge and EGR control, and emission control may all be categorized as higher-level control tasks that can be categorized into subsystems or modules. The position control of actuators and the control of swirl and tumble flaps are two examples of lower-level control operations. Other examples include controlling swirl and tumble valves. These actuators control the air flow, injection mass and angle, rail pressure, EGR flow, camshaft phase, and turbocharger. In most situations, closed-loop control is implemented for the air flow, the

pressure in the common rail, the charging pressure, and, in certain instances, the exhaust gas after-treatment. A great number of feedforward control functions contribute to this.

In addition to the primary control tasks, a number of other sublevel controls must also be implemented. These include position controls for the throttle, injection pumps, camshaft, swirl, and tumble flaps, as well as pressure controls for fuel and lubricating oil. A number of supplementary control functions, such as smoke limitation control (CI), idling-speed control, cold start-up control, and warming-up control, can be activated in response to certain operating situations or states. [CI] stands for smoke limitation control.

The vast majority of feedforward control functions are either implemented as grid-based three-dimensional look-up tables (3D-maps), or as two-dimensional characteristics. This is due to the highly nonlinear static behavior of the IC engines, as well as the microprocessors' accurate interpretation and direct programming using fixed-point arithmetic. However, the majority of the look-up tables and control algorithms are calibrated based on measurements taken on engine test benches and with automobiles. While some of the functions are based on physical models with correction factors, others are not. On the other hand, as the complexity of the engines continues to rise and as the number of variations expands, engine-model-based identification and control-design approaches are becoming increasingly important. As is the case with gasoline engines, the majority of the control functions for an automatic gearbox are carried out by a specialized control unit for the transmission.

2.4 ENGINE DIAGNOSTICS

Both the engine and the chassis of modern cars have become extremely complicated as a result of the dramatic growth in the number of sensors, actuators, mechatronic components, and electronic control units that are included in these vehicles. As a consequence of this, these advancements were accompanied by the incorporation of on-board diagnostics into the vehicle. An on-board diagnosis (OBD I) of emission-relevant components like sensors, actuators, and the ECU has been required for engines by the California Air Resources Board (CARB) since 1988 [11] and by the European Union (EOBD) since 1998. These mandates are primarily responsible for the significant expansion of the development of diagnosis functions. Approaches such as testing electric circuits, verifying plausibility, and examining the limits of measured values are examples of the methods that are utilized. In the interim, these OBD operations consume around fifty percent of the capacity of the ECU. The use of off-board diagnostics in service stations makes it possible to improve problem diagnosis following a cable connection with the testing equipment in a workshop.

2.5 CONTROL SYSTEM DEVELOPMENT

The process of developing electronic management has grown rather complex as a result of the expanding and multi-variable functions of internal combustion engines. As a result of this, the work at hand is quite complicated. The fundamental thermodynamic and mechanical design incorporates features such as the charging cycles, fuel injection, ignition, supercharging, valve train, auxiliary drives, cooling, lubrication, and exhaust gas after treatment, among other things. Experiments can then be carried out on a test bench using a prototype engine that has been modified to include selected actuators, sensors, and a foundational electronic control unit

(ECU). The ability to make systematic measurements on a test bench is granted after first performing a baseline control calibration using a basic control program. Following that, work on optimizing the numerous control functions with the goal of reducing the amount of fuel consumed and the amount of raw emissions produced may begin. The most advanced techniques make use of model-based methods, which are supported by various types of simulations and computer-aided design of elements such as look-up tables for feedforward control and digital control algorithms for feedback control. Designing and calibrating onboard diagnosis functions to meet regulatory standards and support service functions takes additional work. This is done in order to support service functions. The fine-tuning of control functions using automobiles and road testing is the next phase in the process. The design of the shifting or automated gearboxes themselves, whether they are manual or automatic, must also be taken into consideration. Automatic transmissions each have their own electronic control unit (ECU) that is either connected to or incorporated into the housing of the transmission. These ECUs also display an increasing number of control and supervisory tasks. The certification process for emissions is often carried out on roller test benches, which imitate the vehicle's performance while being driven in a longitudinal direction.

2.6 CLASSIFICATION OF INTERNAL COMBUSTION ENGINES BY THEIR CONTROL SYSTEMS

A split into signal-flow-oriented components with physical input and output variables is required in order to construct control and diagnostic functions for internal combustion engines. These functions must be developed. We a total of four engine groups as a result:

- Fundamental pieces of the engine
- Electrical components of the engine
- Manage the computer's hardware and software
- Components that are not essential

as well as further subdivides the matching engine sections and demonstrates the predominate physical mains.

CHAPTER 3: FRICTION AND LUBRICATION

3.1 IN GENERAL

Nearly all of the machine components of an internal combustion engine move relative to one another and come into contact with one another. Lubrication is essential in order to lessen this rubbing action, which also serves to extend the life of the engine. Lubrication in an internal combustion engine serves, in most cases, a dual function, which are as follows:

- To lessen the rubbing action that occurs when various machine elements that are moving relatively to one another interact with one another;
- To get rid of the heat that is created inside the cylinder. Engine friction is defined as the difference between the indicated power (I.P.) (power developed inside the engine) and the brake power (B.P.) (power available at the crank-shaft). It is difficult to eliminate all of the friction loss completely, however it may be decreased by applying lubricant between the components that are in relative motion with each other. An increase in friction eventually results in an increase in the amount of heat that is transferred to the cooling water, which further raises the power needs for the pump and the fan.

The amount of resistance to sliding friction that exists between two moving elements that are moving relative to one another is mostly determined by the following factors:

- The qualities of the lubricating fluid
- The state of the surface
- The components of the surfaces
- The speed of the relative motion
- The kind of the relative motion
- The amount of lubricating oil that is being used

3.2 ENGINE FRICTION

Total engine friction loss is the same as the difference between I.P. and B.P. These losses include (but are not limited to) the following:

- Losses caused by direct friction: It includes losses from bearings like the main bearing and camshaft bearing, as well as friction losses from the piston and cylinder. The frictional losses in reciprocating internal combustion engines tend to be significantly higher.
- Pumping loss: In engines that employ the four-stroke cycle, a significant amount of energy is used during the intake and exhaust stages. Because the incoming fresh mixtures is utilized for recovering the exhaust air and charging the cylinder in two-stroke cycle engines, the pumping loss is almost nonexistent in these types of engines.
- Losses due to blowby: These losses are brought on by the passage of combustion products from the cylinder into the crankcase after they have passed the piston. These losses are contingent on the pressure at the entrance as well as the compression ratio. These losses are proportional to the compression ratio and are worse as it gets higher, but they get better as the engine gets faster.

- Losses caused by the throttling of valves: When it comes to determining how big an exhaust valve should be, it is customary to make it a particular proportion smaller than the intake valves. This often results in an exhaust valve that is of an inadequate size, which in turn leads in a loss in exhaust pumping capacity. If appropriate consideration is not given to the valve size, valve timing, and valve flow coefficients, there is a possibility that an increase in engine speed may result in a significant loss. Because of the limits that are imposed by the air cleaner, the carburetor venturi, the throttle valve, the intake manifold, and the intake valve, the inlet throttling loss occurs. Loss of pressure is the result of all of these limits. In a similar manner, it is important to experience some loss of pressure in order to expel the products of combustion.
- Loss of pressure in the combustion chamber pump: This form of loss is brought on by the pumping work that must be done in order to move gases into and out of the pre-combustion chamber. Consequently, this labor contributes to the loss. The precise value of it is determined by the speed as well as the size of the orifice, which is the passageway that links the fore-combustion chamber to the main chamber. When the speed is increased, the loss also increases, and when the orifice size is decreased, the loss also increases.
- A drop in power that prevents the auxiliary from being: Auxiliary components like a water pump, oil pump, fuel pump, cooling fan, and generator all require some amount of power in order to function properly. This is also considered to be a loss because some of the power that is generated by the engine is used for these other purposes.

The following parameters have an effect on the friction experienced by the engine, as will be discussed below:

- The ratio of the stroke to the bore: The impact of this parameter on both the amount of friction experienced by the engine and its overall efficiency is not very substantial. A lower stroke-to-bore ratio has a tendency to reduce the internal maximum engine pressure. The friction losses are decreased as a result of its lower value because the surface area is reduced in proportion to the lowering stroke-to-bore ratio while the stroke volume remains constant.
- The number of cylinders and the diameter of each cylinder: Both friction and economy are improved when just a few big cylinders are utilized instead of many smaller ones. This is because there is a smaller ratio between the area of the working piston and the area of the piston that is responsible for causing friction, which is the circumference.
- Piston rings: Because the selection of the number of piston rings relies on the size of the engine, the desired level of lightweight, and the material used for the rings, the influence of the number of piston rings on friction is not substantial.
- Compression ratio: When the compression ratio is raised, there is a corresponding rise in the frictional mean effective pressure. However, there is a possibility that the i.m.e.p. improvement will even result in an increase in the mechanical efficiency.
- Engine speed: When the speed is increased, the amount of mechanical friction also increases.
- Weight of the Engine: When there is a greater demand placed on the engine, the internal mechanical energy output (i.m.e.p.) likewise rises, as does the amount of frictional loss. However, this increase in friction loss is compensated for by a reduction in viscosity of the lubricating oil owing to greater temperature as a consequence of increased load. This higher temperature is a direct result of the increased load.

- The temperature of the cooling water: Because oil's viscosity decreases with increasing temperature, frictional loss may be reduced by increasing the temperature of the cooling water. This is because higher temperatures cause oil to have a lower viscosity.
- The thickness of the oil: The higher the viscosity of the oil, the greater the loss of energy due to friction. Within a given temperature range, the viscosity of the oil will decrease as the temperature rises, which will result in less waste of energy due to friction. If the temperature is high enough, the local film will be ruined, which will result in metals coming into direct touch with one another.

The following five approaches may be used to calculate the amount of friction in the engine:

- Derived from the measurements of the I.P. and B.P.
- Morse test
- Willian's line approach as the third option
- Mode of transportation
- The mechanism of deceleration

3.3 LUBRICATION

Lubrication is achieved by allowing oil to pass between two surfaces that are moving in close proximity to one another. The following is a list of items that might be considered candidates for lubrication:

- To lessen the amount of friction that occurs between the pieces that are moving relatively.
- In order to decrease the amount of wear on the moving portion.
- To prevent the surfaces from overheating by removing the heat that is produced by friction.
- To close off an area between two neighboring surfaces.
- To act as a shock absorber between the bearings and the other components, which will ultimately result in a reduction in noise.
- To clean any debris or grit that may have been lodged between the rubbing components.

It is possible to draw the following conclusions on the factors that influence bearing performance:

- It is preferable to choose a bearing material that is slippery while beginning and halting, but after the oil film has been produced, the bearing material becomes less significant.
- If the speed of the journal is increased, then a greater amount of oil will be drawn into the apex of the wedge of oil that is located in the clearance gap. As a consequence, a greater amount of supporting pressure will be generated.
- An increase in the supporting pressure will cause the oil film thickness r to grow, while simultaneously causing an eccentricity e decrease.
- The eccentricity, denoted by e , must be reduced for the supporting pressure to decrease; this is due to the sides of the wedge being brought closer to being parallel.
- Altering the clearance also has an effect on the thickness of the oil film, denoted by r .

Film lubrication is the form of lubrication in which the bearing surfaces are fully separated by a layer or film of lubricant, and the only thing that causes frictional resistance is the relative movement of the lubricant layers. This type of lubrication is known as "film lubrication".

Lubrication at the Boundary: Under hydrodynamic conditions, the oil film will sustain the load. In the event that the oil film becomes sufficiently thin to prevent it from supporting the load without the occurrence of occasional metal-to-metal contact, the friction that develops in the journal is referred to as boundary friction, and the lubrication that exists in this range is known as boundary lubrication. Because journal friction is neither totally dry nor completely fluid under these circumstances, the term "boundary friction" is employed instead. When in the border state, the degree of journal friction is affected by the kind of bearing material, the hardness and surface quality of the shaft, as well as the type of lubricant. When there is a very high load operating on the bearings, the material itself will bend elastically against the pressure that is built up by the oil film. When the contact pressures are exceptionally high, a particular kind of lubrication known as elasto-hydrodynamic lubrication may take place between cams and followers, gear teeth, and rolling bearings.

3.4 LUBRICANTS AND THEIR VARIOUS PROPERTIES

When choosing an oil for lubrication, the following characteristics are the most important to look for:

1. **Viscosity:** It is the capacity of the oil to resist internal deformation due to mechanical stresses, and as a result, it is a measure of the ability of the oil film to bear a load. The ability of the oil to resist internal deformation owing to mechanical stressors. A more viscous oil may carry a larger weight than a less viscous oil, but the amount of friction it offers to the sliding action of one bearing surface over the other will be greater. Because temperature has an effect on viscosity, it is important that a surface that has to be lubricated be supplied with oil that has a greater viscosity if the surface is typically at a high temperature. A viscosimeter is used to determine the level of viscosity. The following are the main categories of viscosimeters:
 - a. Saybolt universal viscosimeter
 - b. A viscosimeter made of red wood
 - c. Engler viscosimeter
 - d. Barbey viscosimeter.

It is common practice to refer to the unit of viscosity as "seconds saybolt" or "seconds redwood," etc. The viscosity index of an oil is the way that is used in the current day for the purpose of indicating the rate at which the viscosity of an oil will vary in response to temperature changes (V.I.). The viscosity of the oil is measured against two reference oils that have the same value at 99 degrees Celsius. The first is a paraffinic base oil, which has a viscosity that varies significantly with temperature and is arbitrarily given an index of zero. The second is a naphthenic base oil, which has a viscosity that varies very little with temperature and is assigned an index of 100.

A high viscosity index suggests that there is significantly less of a shift in the oil's viscosity as the temperature varies. When compared to a substance with a lower

viscosity index, a liquid's rate of viscosity reduction when subjected to a rise in temperature is slower. It should be emphasized that viscosity-temperature characteristics are of little importance for oils that are to function at approximately constant temperature, such as turbine oils, even though a high viscosity index is desirable in materials and a lot of effort has been expended in improving the viscosity index of oils by refining. Despite the fact that a high viscosity index is desirable in materials and that a lot of effort has been expended in improving the viscosity index of oils by ref The viscosity index of the oil should be carefully considered in environments with very high temperatures. Certain chemicals, which are referred to as viscosity index improvers, are added to oil in order to make the oil have a higher viscosity index. These are long chain paraffinic compounds, and they allow for the production of an oil that combines the ease of beginning that is typical of thinner oils with a robust resistance to the damaging effects of high temperatures.

2. Ignition temperature: It is the minimum temperature at which the lubricating oil will flash when a tiny flame is carried over its surface. It is defined as the temperature at which it can be measured. The flash point of the oil need to be sufficiently high so as to prevent the spontaneous combustion of oil vapors at temperatures that are typically seen in everyday operation. Oils with a high flash point are required for use in air compressors.
3. Fire point: It is the degree at which the oil burns steadily for the longest period of time. Lubricating oils need to have a high fire point in order to prevent the oil from catching fire while it is being used.
4. Cloud point: The liquid condition of the oil transforms into a plastic or solid state when it is exposed to temperatures below its melting point. In certain instances, the oil may start to harden, which will cause it to have a hazy appearance. The temperature at which this transition from clear to cloudy skies takes place is referred to as the cloud point.
5. Pour point: The temperature at which the lubricating oil has reached its pour point is referred to as the pour point temperature. This is an indicator of how well it can move when the temperature is low. This quality has to be taken into consideration because of the influence it has on the ease with which an engine can be started in cold weather and on the free circulation of oil via outside feed lines when pressure is not being applied.
6. Greasiness: This is the quality that permits oil to stick to the surface of the bearing and to distribute evenly throughout its whole surface. Lubrication of boundaries is where it shines the brightest.
7. Rustiness: A lubricant shouldn't corrode the moving components, and it should be able to keep its properties even when it's mixed with other substances or has additives added to it.
8. formation of emulsions: When lubricating oil is combined with water, the oil becomes emulsified and loses its ability to glide over surfaces smoothly. An indicator of an oil's propensity to form an emulsion with water is referred to as the emulsification number.
9. a state of physical steadiness: It is essential for a lubricating oil to maintain its physical properties at temperatures ranging from its absolute minimum to its absolute maximum

range of operation. At the very lowest temperature, there shouldn't be any separation of the solids, and at the very highest temperature, it shouldn't be possible for it to vapourize beyond a particular limit.

10. Stability of the chemical: Additionally, the chemical stability of a lubricating oil is essential. It is not acceptable for there to be any propensity for oxide formation.
11. Neutralisation number: When an oil is refined, certain contaminants may remain in the oil even after the process is complete. The neutralisation number test is a straightforward method that may be used to establish if an oil is acidic or alkaline. It is the amount of potassium hydroxide, measured in milligrams, that must be added to one gram of oil in order to neutralize the acidity of the oil.
12. Adhesiveness: Because of this feature of lubricating oil, the oil particles will adhere to the metal surfaces they come into contact with.
13. The tensile strength of the film: Even when both the speed and the load are increased, a lubricating oil will still maintain a thin coating between the two surfaces it is lubricating since it has this feature. Both the film and the surfaces remain intact and do not come into direct touch with one another. Because of its adhesiveness and film strength, the lubricant is able to enter the pores of the metal and cling to the surfaces of the bearings and journals, thereby keeping those surfaces moist even when the journals are not in motion and ensuring that metal surfaces remain in contact with one another until the lubricant film is completely built up.
14. The specific gravity: It is a measurement that indicates how dense oil is. When one kind of lubricant is compared to another, the result gives an indicator of the quality of the lubricant. It is measured with a hydrometer that floats in the oil, and the gravity is read off of the scale that is located at the top of the oil on the hydrometer.

Mineral and vegetable oils are the two primary categories of oils that are available. They both satisfy some of the fundamental conditions that should be met in a lubricating oil. Even though vegetable oil is preferable to mineral oil in some severe situations, it is not very often utilized since vegetable oil is much more costly than mineral oil. Mineral oils are an extremely popular choice for usage in a variety of lubrication contexts. Mineral oils that aren't refined contain the majority of the desirable qualities needed to be a good lubricant. However, due to the various working circumstances, it is unable to satisfy the requirements for some specialized features, such as having a high viscosity index and being resistant to oxidation and corrosion. Additives are various sorts of substances that are put into a substance in order to bring about the desired changes in its qualities.

1. Detergents may prevent deposits from forming at high temperatures, such as gums, and if they are used in excess, they can also be used as an efficient acid neutralizer.
2. Controlling low-temperature deposits, such as cold sludge and varnish deposits, is the primary function of dispersants.
3. Anti-wear additives: These additives prevent scoring, galling, and seizure in addition to reducing the amount of wear that occurs. They provide the additional strength that is required to guarantee effective lubrication even under the most demanding working circumstances. Chlorine and phosphate chemicals make up the additives that are used.

4. Rust inhibitors: Decrease the amount of rusting that occurs via the acid neutralization and creation of protective coating.

5. Viscosity index (V.I.) improver: It stops the oil from becoming too thin as the temperature rises; it also has the following benefits: Lubricating oils should always have a high viscosity index so that they may be used in extreme temperatures, both during the winter and the summer. Because of their solubility in the oil, high-molecule polymers are often used for this purpose. Recently, multigrade oils have been manufactured, which are distinguished by their combination of oils with low viscosity and polymers with increasing thickness. One of their unique abilities is the capacity to adapt to both warm and cold environments.

6. Pour point additives: The basic oil, when subjected to temperatures so low that wax crystals form, transforms into solids that have the consistency of butter. If nothing is done to prevent it, the wax crystals will eventually form a honeycomb-like structure, which will first restrict, and then completely stop, the flow of oil. These chemicals interfere with the crystallization of wax, which results in a lower pour point for the oil. Up to one percent of the oil might be comprised of polymerized phenols or esters depending on the application.

7. Anti-foam agents reduce oil foaming by forcing the bubbles in the oil to collapse owing to the entrainment of air. Silicon esters are employed as antifoam agents.

8. Anti-oxidants: They prevent the oxidation of oil, which protects alloy bearings from corrosive damage.

9. An improvement in oiliness is provided by the following: The addition of certain compounds, such as colloidal graphite and zinc oxide, to the oil is helpful in preserving the oil layer.

After a given amount of time in use, the lubricating oil will get polluted to the point that it will no longer be appropriate for further application. The contamination of the oil may be attributed to a number of different factors, including oxidation, dilution, water, the creation of carbon and lead compounds, metals, dust, and dirt. Sludge is produced in an engine whenever these pollutants are allowed to combine with the oil there.

Sludge is a deposit that might be black, brown, or gray in color and has the consistency of mud. When the engine is started, warmed up, or idled, all of these activities occur at temperatures that are too low to prevent the production of this deposit.

3.5 LUBRICATION SYSTEMS

The following is a list of the primary components of an engine that need lubrication:

- The bearings for the main crankshaft.
- Big-end bearings.
- Small end bearings, sometimes referred to as gudgeon pin bearings.
- Gears used for timing.
- Valve mechanism.

- Piston rings and the walls of the cylinder.
- The camshaft and the bearings for the camshaft.
- Valve guides, valve tappets and rocker arms.

Different types of lubrication systems that are used for internal combustion engines may be categorized as follows:

- A lubricating system that uses a wet sump.
- A lubricating system for the dry sump.
- A lubricating system that uses mist.

3.5.1 LUBRICATION SYSTEM FOR THE WET SUMP

These systems make use of a big capacity oil sump that is located at the base of the crankchamber. The oil is extracted from this sump by a low pressure oil pump and then distributed to the different components of the system. After it has completed its function, the oil there will eventually make its way back to the sump.

1. This mechanism (Figure 13: Splash lubrication system) may be seen on a few of the smaller stationary four-stroke engines. In this instance, the caps that sit atop the big end bearings of connecting rods are equipped with scoops. These scoops, when the connecting rod is in its most downwardly positioned position, simply dip into oil troughs. This causes the oil to be directed through holes in the caps and into the big end bearings. As a result of oil splashing, it makes its way to the bottom section of the cylinder walls, the crankshaft, and any other components that need to be lubricated. The oil that was used up ultimately makes its way back to the oil sump. The amount of oil in the troughs is kept constant with the assistance of an oil pump that draws oil from the sump after it has been filtered.

The splash system is appropriate for engines operating at low to medium speeds and exhibiting moderate bearing load pressures. This method is not suited for high-performance engines, which often run at high bearing pressures and rubbing speeds during operation.

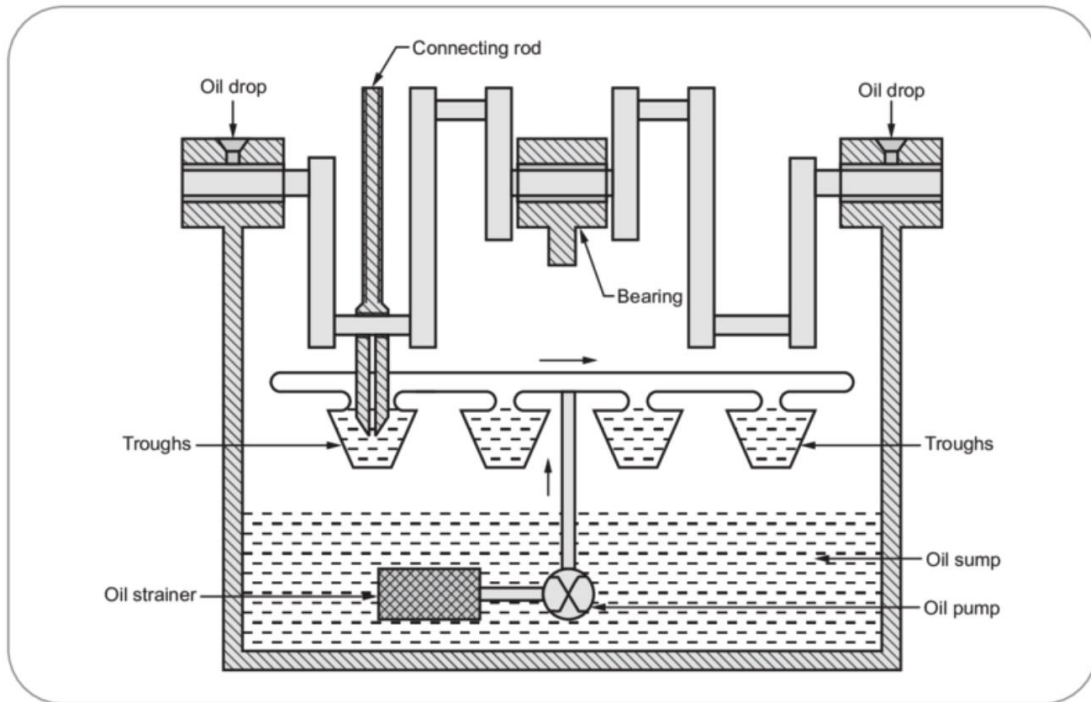

Figure 13: Splash lubrication system [19]

2. Semi-pressure system: This technique utilizes both splash and pressure systems to get the desired results. It takes the good points from each and combines them into one. The primary source of oil in this instance may be found in the bottom of the crank chamber. The oil for the main bearings is extracted from the bottom part of the sump, passed through a filter, and then given to the bearings by means of a gear pump at a pressure of around 1 bar. The lubrication of the large end bearings is accomplished by spraying a lubricant via nozzles. Because of this, oil also serves to lubricate the cams, the bearings on the crankshaft, the cylinder walls, and the timing gears. There is an oil pressure gauge available to determine whether or not there is sufficient oil supply. Installing this system will cost far less than installing a pressure system. In comparison to the splash system, it permits the use of larger bearing loads as well as engine speeds.

3. Full pressure system: When using this technique, oil is pushed under pressure from the oil sump to the different sections of the machine that need to be lubricated. A gear pump is used to move the oil once it has been withdrawn from the sump, passed through the filter, and then pumped. At a pressure range from 1.5 to 4 bar, the pressure pump is responsible for delivering the oil. The major bearings of the crankshaft and camshaft receive oil that is pressurized and fed to them. Oil may be communicated to both the large end bearing and the small end bearings via holes punched in the connecting rods. These holes are drilled through the bearing journals of the main crankshaft. A pressure gauge is provided so that one may verify that oil is being distributed to all of the necessary locations. On the delivery side of this pump is also located a pressure regulating valve, which is there to prevent the pressure from being too high. Due to the fact that it enables high bearing pressure and rubbing speeds, this system is favored by the majority of the engine manufacturers.

3.5.2 LUBRICATION SYSTEM FOR THE DRY SUMP

The oil from the sump is transferred with this arrangement to a separate storage tank that is located outside of the cylinder block of the engine. The oil from the sump is pushed using a sump pump all the way to the storage tank, where it is filtered along the way. The oil in the storage tank is poured via the oil cooler and into the cylinders of the engine. The oil pressure may range anywhere from three to eight bars. For big capacity engines, the dry sump lubrication system is often chosen as the best option (Figure 14: Dry sump lubrication system).

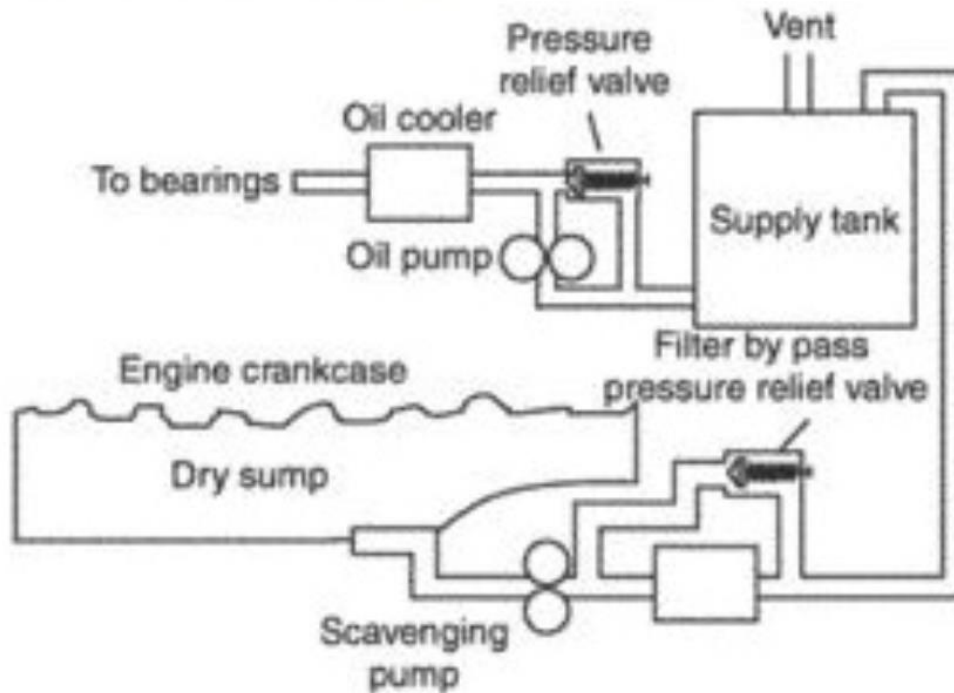

Figure 14: Dry sump lubrication system [20]

3.5.3 SYSTEM LUBRICATION MIST

Engines that operate on a two-stroke cycle make use of this mechanism. The majority of these engines are crankcharged, which means that the crankcase is used to compress the air, and as a result, they are not appropriate for crankcase lubrication. The gasoline tank receives between 2 and 3 percent of lubricating oil, which is then added to the engine to lubricate it. The carburetor is responsible for inducing the oil and fuel combination into the engine. The gasoline is turned into vapor, and oil, in the form of a mist, is introduced into the cylinder by way of the crankcase. Lubrication of the main and connecting rod bearings is provided by the oil that comes into contact with the crankcase walls. Lubrication of the piston, piston rings, and cylinder is provided by the remainder of the oil that comes into contact with the cylinder during the charging and scavenging phases. The F/A ratio that is employed is also an essential consideration for excellent performance. The ideal F/A ratio is somewhere between 40 and 50 to 1. When the ratio is too low, spark plug fouling occurs, and when the ratio is too high, the rate of wear increases.

Advantages:

1. System is simple
2. A low price (because no oil pump, filter etc. are required).

Disadvantages:

1. The combustion of some lubricating oils results in the production of significant quantities of exhaust emissions and deposits on the piston crown, ring grooves, and exhaust port, all of which work to impede the engine's capacity to function well.
2. Because the lubricating oil comes into touch with acidic vapours created during the combustion process, it quickly loses its anti-corrosion qualities, which ultimately results in corrosion damage to the bearings.
3. For the lubrication to work properly, the oil and gasoline have to be well combined. This necessitates either the mixing of the oil in a separate container before use or the addition of some substance in order to impart favorable mixing characteristics on the oil.
4. The crankcase oil is diluted because the exhaust temperature is greater and the scavenging efficiency is lower than normal. In addition, a little amount of lubricating oil is used during the combustion process. Because of this, the amount of lubrication required for a two-stroke engine of a comparable size is increased by 5 to 15 percent.
5. Since there is no way to regulate the amount of lubricating oil that is mixed in with the fuel after it has been added, the majority of two-stroke engines are often over-oiled.

3.5.4 VARIOUS COMPONENTS OF THE ENGINE RECEIVE LUBRICATION

Lubrication of main bearings: With the assistance of a ring (or chain) type feeder, the main bearings are lubricated in a manner that is considered satisfactory. Figure 15[21] provides an illustration of the ring oiling system. It is made up of a ring that has a diameter that is much greater than that of the shaft. At the top of the bearing cap, there is a single groove, and the ring is positioned on the shaft. A portion of the ring's bottom surface is submerged in an oil reservoir. The rotation of the shaft causes the ring to revolve at a slower pace, and it is this slower speed that allows the oil to be transferred from the reservoir to the bearing. The adhesion principle underlies the operation of this system. Within the confines of this system, the lubricating oil can only be supplied while the shaft is actively turning. Chains are often used in place of rings in certain situations.

Because the oil will be flung off owing to centrifugal force at high speeds, and the volume of oil transported is insufficient at low speeds, this sort of lubrication is more helpful for engines that operate at a medium speed than those that operate at either high or low rates.

Lubrication of the cylinder and the small end bearing of the connecting rod: A drip system is used to lubricate the cylinder, the small end bearing (gudgeon pin), valve gear pins, rocker shaft, crankpins, and other components. In a system known as a drip system, machine components get oil one drop at a time from an oil cup. Even if it is not an effective strategy, using grease to lubricate the moving components of machines and engines is sometimes the method that offers the most convenience. This method is used to lubricate a wide range of machine and engine components, such as valve gear pins, rocker shafts, small engine primary bearings, crank-pins,

cross-head pins, line shaft bearings, and many others. Glass is used for the oil reservoir or cup that is included in this item. There is a hole at the top of the cup that is referred to as the filling hole, and it is through this aperture that the lubricating oil is poured into the cup. The oil seeps into the inner chamber via the holes, and as a result of gravity, it drips down the nozzle in ever smaller amounts. A needle valve is used to regulate how much oil is allowed to go through the nozzle. There is a sight feed glass supplied so that you can see the individual drips of oil.

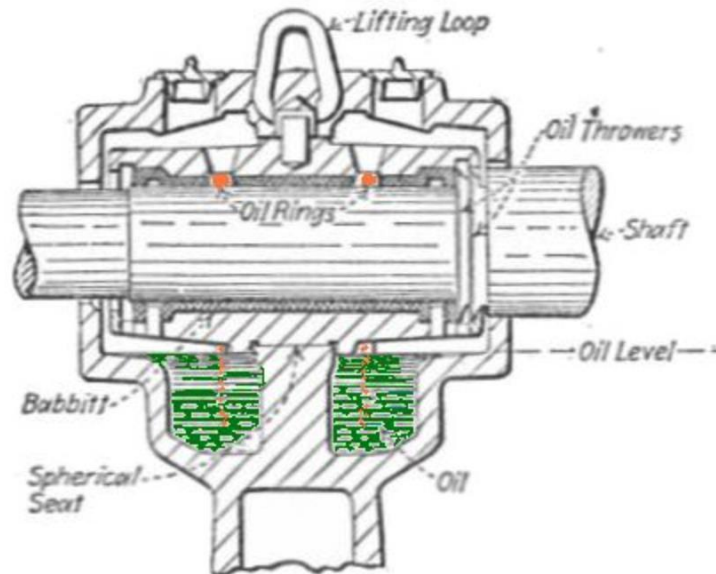

Figure 15: Ring oiling system [21]

Lubrication of the crank and gudgeon pin: The oil that is found in the crankcase is used to coat the connecting rod. When the machine is rotating, the centrifugal force causes the oil to splash, and this causes the oil to go to the various components of the machine that need it. It is recommended to use this kind of lubricant at crankshaft speeds of at least 200 revolutions per minute. At regular intervals, the oil should either be filtered or replaced. In addition to this, the oil level should be kept at the appropriate level.

Lubrication is applied to the ball bearings and roller bearings for the following reasons:

- To lessen the amount of wear and friction that occurs between the components of the bearing that slide.
- To protect the bearing surfaces from developing rust or corrosion.
- To shield the bearing surfaces from moisture, dirt, and other contaminants.
- To reduce the intensity of the heat.

In order to keep the ball and roller bearings lubricated, oil or a little grease is often applied to them. It is essential that only pure mineral oil or a grease with a calcium basis be used. Potassium or sodium-based greases may be utilized if there is even a remote chance that they will come into contact with moisture. Grease has a number of benefits, one of which is that it may be used to create a seal that will prevent dust or any other unwelcome material from

entering. The temperature should be maintained at or below 90 degrees Celsius, and a bearing should never be allowed to run at or beyond 150 degrees Celsius.

Before it can be provided to the engine bearings, all of the lubricating oil that comes from the oil sump is required to be filtered by an oil filter. Lubricating oil is used to prevent friction and wear in moving parts. Bearings operate with very precise tolerances, thus any foreign abrasive material that makes its way into the lubrication system runs the risk of causing damage to the bearings.

Both of the following configurations are possible for the filter assembly:

- The kind with a bypass
- The type with a full flow

The by-pass type filter arrangement: in this arrangement, only a small portion of the lubricating oil is allowed to pass through the filter. The remaining lubricating oil is then directly supplied to the bearings by the oil pump at a pre-set pressure, which is determined by the pressure regulating valve. 2. The cartridge filter arrangement: In this arrangement, only a small portion of the lubricating oil is allowed to pass through the filter. As a direct consequence of this, a part of the oil gets filtered continuously. An extremely tiny filter or a specific filter coated with resin is employed since the amounts of oil passing through the filter are minimal. This is done to prevent the filter from falling apart as a result of moisture. This kind of thin paper or filter will eliminate any and all potentially hazardous pollutants.

Filter arrangement of the full-flow type: in this kind of filter arrangement, the whole of the oil is filtered before being distributed to the individual bearings. As a result, the dimensions of the filter are on the substantial side. Because of the high pressure that is necessary to pump oil through filters of this kind, it is almost impossible to remove extremely tiny particles in this scenario. In the usual course of business, each and every drop of lubricating oil needs to be filtered about every half minute. In order to avoid an excessive amount of pressure from building up after a cold start, a pressure release valve is used.

CHAPTER 4: NATURAL GAS COMBUSTION ENGINES

4.1 IN GENERAL

R&D on internal combustion engines that can achieve higher fuel conversion efficiency and reduced emissions formation compared to currently available spark-ignition (SI) and diesel engines has been prompted by global regulations regarding fuel economy and emissions. These regulations have led to the development of these engines. The term "homogeneous charge compression ignition," or HCCI for short, was coined by Najt and Foster in 1983 and has since given rise to a plethora of other advanced combustion ideas that have been presented in the scientific literature [12]. The homogenous charge of premixed SI engines and the internal combustion of diesel engines are brought together in the HCCI idea, which results in the creation of a lean burn concept that is capable of achieving great thermal efficiency. The low oxygen content of the mixture leads to a low burnt gas temperature, which in turn prevents the generation of thermal NO_x during combustion. The low temperature of the burnt gas has inspired many researchers to adopt the phrase "low-temperature combustion" to describe this idea. This word has now been used to embrace not just this concept but also other combustion concepts of a type that are comparable to this one.

Combustion through HCCI is accomplished by first producing a homogenous and lean combination of fuel and air, and then compressing this mixture until it reaches the point of autoignition. This causes a heat release process that is initiated and controlled by chemical kinetics. This process is different from the heat release that occurs in SI engines, which is controlled by turbulent flame propagation. It is also different from the heat release that occurs in diesel engines, which is governed by diffusion mixing between the fuel that is directly injected and the air that is present. In HCCI engines, the lack of a spark or direct fuel injection means that there is no possibility of exercising direct control over the beginning of the combustion process. Therefore, the timing of the ignition can only be controlled in an indirect manner. This may be accomplished by manipulating the air-to-fuel ratio of the mixture, the dilution level, and the temperature of the initial mixture.

The feasibility of the HCCI concept has been demonstrated through the use of experimental testing in single-cylinder optical and metal engines [13] [14], as well as in light-duty and heavy-duty commercial engine platforms [15] [16]; It has been shown through experimentation that HCCI combustion may take place at very lean ratios while maintaining a high compression ratio. This results in not only good thermal efficiency but also low levels of NO_x and no soot creation. The homogenous nature of the mixture, on the other hand, causes bulk autoignition as well as a high heat release rate and pressure increase rate inside the cylinder. These factors combine to restrict the maximum load that can be carried by the cylinder. Ignition of a lean fuel-air combination by compression alone needs charge heating, which may be achieved either by intake air preheating or by residual gas trapping in the cylinder. In addition, charge heating is required for the process of igniting a low fuel-air mixture [17].

Researchers have suggested strategies to impart heat and chemical layering to the mixture and span the autoignition process as a means of mitigating the high heat release rates that are caused by the combustion of HCCI. Using split fuel injections straight into the cylinder is one method that has been suggested by Dec J.E. et al. (2015) [18] and Yang Y. et al. (2012) [19]. This method is referred to as "partial fuel stratification" (PFS). Because the injection process is

divided into early and late injections, the mixture can become compositionally and thermally stratified. This ultimately leads to sequential autoignition all through the combustion chamber. Another method that was proposed by Lawler B. et al. (2017) is called direct water injection [20]. This method involves injecting water into a premixed fuel–air mixture in order to forcibly stratify the thermal field within the cylinder through the evaporation process of water and therefore hold back the autoignition process.

Researchers have suggested the use of two fuels as an additional approach to managing the energy release of low-temperature internal combustion. These methods are in addition to the techniques discussed above. The Reactivity Controlled Compression Ignition (RCCI) concept, which was proposed by Kokjohn S. L. et al. (2013) combines a fuel with a low reactivity that is injected at the port (for example, gasoline) with a fuel with a high reactivity that is injected directly into the cylinder in order to produce a compositional stratification within the combustion chamber [21]. Staggered autoignition and reduced heat release rates are the results of the mixing of the two distinct fuels in the combustion chamber, which generates zones of varying reactivity. This is in contrast to HCCI, which does not involve mixing the fuels. The RCCI combustion idea has been proven in both light-duty and heavy-duty engines, where it has exhibited strong controllability and fuel conversion efficiency comparable to diesel engines. The combustion process is lean and takes place at low temperatures, which prevents the formation of thermal NO_x. However, the direct fuel injection of the high-reactivity liquid fuel results in some particulate emissions, albeit at levels that are significantly lower than those produced by conventional diesel combustion.

Because of their broad use in the commercial sector, gasoline and diesel fuels have been the primary focus of the majority of the research conducted on low-temperature combustion principles such as HCCI and RCCI. However, a number of studies have concentrated on investigating advanced combustion using natural gas as an alternative to liquid fuels that may provide answers for sustainable transportation and power production. These studies have been conducted in recent years.

4.2 COMBUSTION OF NATURAL GAS USING HCCI

There has been research done on the possibility of using HCCI combustion with natural gas in larger trucks, locomotives, and static power generation. However, in order to accomplish autoignition, a larger compression ratio and/or a higher heat addition to the fuel–air combination are required when using natural gas as opposed to gasoline, due to the higher Research Octane Number (RON) of natural gas. Aceves S. M. et al. (1999) explored the influence of compression ratio on combustion by doing computational fluid dynamics (CFD) simulations of a supercharged HCCI engine utilizing methane and including extensive chemical reactions [22]. Equivalence ratio and the captured Residual Gas Fraction (RGF) were shown to be effective means of controlling the combustion process; nevertheless, high-speed cylinder pressure monitoring was required in order to achieve the desired level of control. The peak in cylinder pressure and the development of NO presented a threat to the engine's capacity to handle a high load. This modeling investigation was extended by Flowers et al. using real natural gas composition, and they explored the influence of different fuel compositions on HCCI combustion (Flowers et al. 2001). It was discovered that the combustion of HCCI was sensitive to the composition of natural gas; thus, active management is necessary in order to correct for fluctuations in composition that are common all over the globe. Changes in the composition of natural gas may cause the peak heat release time to move forward or backward by up to ten

crank angle degrees (CADs), which has a substantial impact on efficiency as well as the creation of pollutants. The amount of propane and butane that is contained in natural gas has the potential to have a major impact on the combustion of HCCI. These three control strategies, which were discovered to be efficient in controlling the rate of heat release over a wide range of operating conditions, were proposed: (i) adding Dimethyl Ether (DME) to the fuel–air mixture; (ii) intake gas preheating; and (iii) using hot Exhaust Gas Recirculation (EGR). (i) Adding Dimethyl Ether (DME) to the fuel–air mixture; (ii) intake gas preheating; and (iii)

There is an experimental test and modeling on a heavy-duty natural gas HCCI engine working at 1000 rev/min with a λ of 0.3 to investigate the sensitivity of HCCI combustion to fuel composition. The engine was operating under the following conditions: The inclusion of higher order hydrocarbons led to an increase in the combination's reactivity and a decrease in the temperature at which the mixture might spontaneously ignite. Ethane had a sensitivity of 1.0 °C/%, butane had a sensitivity of 2.5 °C/%, and propane had a sensitivity of 1.5 °C/%. It was determined, on the basis of the findings of the experiment, that variations in the composition of natural gas might potentially result in high-speed or low-speed impacts on the performance of the engine.

A comparable experimental investigation was carried out by Olsson J. O. et al. (2002), utilizing a heavy-duty engine that had been adapted for natural gas HCCI combustion [23]. In addition, modeling of the same engine was carried out in order to investigate the impact that compression ratio had on combustion. On a cycle-by-cycle basis, regulation of the combustion phasing was achieved by the use of hydrogen enrichment. The compression ratio was changed from 15:1 all the way up to 21:1, but it was found to have only a little impact on the pace at which heat was released. A high compression ratio led to greater peak cylinder pressures, but it also allowed the engine to run leaner, which decreased the amount of NO_x that was produced. Overall, the compression ratio should be high enough to allow for lean running with minimal NO_x at high load while still offering sufficient control authority at maximum load. This is the ideal situation.

Using a light-duty research engine equipped with residual gas trapping, Yap D. et al. (2006) investigated the impacts of adding hydrogen on natural gas HCCI combustion to see how it would affect the reaction. The hydrogen was generated by an exhaust-assisted reformer, and it was delivered to the cylinder in the form of hydrogen-rich exhaust gas recirculation (EGR). The need for the intake air to be preheated prior to autoignition was reduced as a direct consequence of the inclusion of hydrogen in the fuel–air combination [24]. Nevertheless, some intake air preheating was necessary in conjunction with residual gas trapping; this was the case even after the addition of hydrogen to the system. However, the inclusion of hydrogen resulted in greater cylinder temperatures at high loads and increased NO_x when compared to pure natural gas HCCI. This was because the advantage of hydrogen in decreasing the autoignition temperature was more efficient at low loads than it was at high loads. Yap et al. used low-temperature exhaust gas fuel reforming in later trials, which resulted in the production of reformat gas containing up to 16% hydrogen by volume. In order to exert control over the autoignition process, this reformatted gas was sent back to the intake, where it was combined with the new natural gas–air combination. It was discovered that the intake air preheating required for autoignition might be lowered with the addition of hydrogen to the mixture.

The closed-loop operation of the engine and the reformer demonstrated that the addition of hydrogen increased stable HCCI operation and extended the low load limit without decreasing the efficiency of the combustion process. The addition of hydrogen-rich reformat gas resulted in a reduction in NO_x emissions; however, this was offset by an increase in CO and incomplete

combustion hydrocarbon emissions (UHC). The addition of hydrogen also had some marginally beneficial effects on the particular fuel consumption that was revealed. The amount of water that is present in the exhaust gas contributes to the rise in the generation of hydrogen in the reformer, which in turn compensates for the amount of energy that is lost as a result of the oxidation processes.

To examine the combustion characteristics and phasing techniques of a natural gas HCCI engine, Soylu modeled the engine using a zero-dimensional model. Controlling the equivalence ratio, as well as the temperature and pressure conditions at Intake Valve Closing (IVC), is essential for controlling the combustion phasing. This can be accomplished through the utilization of Variable Valve Actuation (VVA), Variable Compression Ratio (VCR), and Exhaust Gas Recirculation (EGR). On the other hand, it was discovered that raising the EGR percentage led to a decrease in both the maximum achievable thermal efficiency and load. It was discovered that the addition of propane to mixes of natural gas and air was helpful in managing combustion phasing, despite the fact that this control method was a low-speed control option. At an IMEPn pressure of 4–5 bars, it is possible to attain a fuel conversion efficiency of 45%, provided that effective combustion phasing control is accomplished.

The use of natural gas HCCI engines for stationary power production, such as distributed generation and Combined Heat and Power (CHP) systems, has also been investigated. Kobayashi et al. undertook experimental testing initially on a single-cylinder research engine initially, and subsequently on a four-cylinder turbocharged engine as part of their investigation into the possibility of employing a 50 kW natural gas HCCI engine in a CHP system. This testing was undertaken by Kobayashi et al (Kobayashi et al. 2011). According to the findings of many experiments, the load range of turbocharged HCCI engines may be able to surpass that of normally aspirated SI engines (Fig. 2.2). By increasing the engine compression ratio and lowering the boost pressure, it is possible to achieve excellent thermal efficiency while simultaneously reducing NOx emissions to an exceptionally low level when the peak cylinder pressure is restricted. It was confirmed that natural gas HCCI has the potential to provide high efficiency and low emissions for CHP applications because the 4-cylinder turbocharged HCCI engine achieved 43.3% thermal efficiency at 0.98 MPa bar Brake Mean Effective Pressure (BMEP) and 13.8 ppm engine-out NOx emissions.

4.3 ADVANCED COMBUSTION OF DUAL FUELS

While HCCI ignition using natural gas has been experimentally demonstrated, and despite the fact that its performance and pollution advantages have been recorded, the higher and lower engine loads that can be achieved are limited because of the significant heat release rates that occur during combustion. Researchers have adopted dual-fuel combustion, which brings chemical layering to the air–fuel mixture and results in a sequenced autoignition process, in order to minimize the heat release rates. This technique was developed in order to improve efficiency. Experimental testing in the past was carried out on a heavy-duty John Deere natural gas engine. The engine had been converted to run on the dual HCCI combustion system at low to medium loads. Port fuel injectors were installed in the engine, and they were used to inject Fischer–Tropsch (FT) ethane fuel that had 1000 parts per million (ppm) of ethyl hexyl nitrate (EHN) added to it so that it would have better autoignition properties. The combination of natural gas and air that was injected upstream in the intake manifold was made richer by the addition of the liquid fuel. Dual-fuel HCCI operation was accomplished from idle all the way

up to 5.5 bar BMEP, which corresponds to about 35% of the maximum engine torque. Fuel blending proved to be an efficient method for controlling the rates of heat release in HCCI mode, which were much greater than those in SI operation. When compared to SI operation, HCCI operation resulted in up to 15% greater fuel conversion efficiency gains while simultaneously resulting in a reduction of NO_x by 95% to 99%. However, under the same circumstances, HCCI operations produced much greater levels of CO and UHC pollutants than SI operations did.

On a single-cylinder DI diesel engine, Papagiannakis R. G. et al. (2004) performed experimental tests of dual-fuel natural gas–diesel combustion [25]. A premixed combination of natural gas and air was used to power the engine, and autoignition was kept under control with the fuel injection of a very small quantity of diesel fuel. When compared to traditional diesel combustion, dual-fuel operation led to a significant reduction in both the rate of heat release and the rate of pressure rise. Dual-fuel operation produced a lower fuel efficiency than diesel while operating at low loads, but when operating at high loads, it was just as efficient as diesel. Dual-fuel operation, in every instance, demonstrated a reduced burning rate, which resulted in lesser NO_x production compared to normal diesel combustion. This was the case regardless of the fuel type being used.

Kong conducted research on natural/DME HCCI combustion by utilizing CFD equipped with comprehensive chemical kinetics. He then compared the modeling findings with actual data from a single-cylinder Yanmar diesel engine that had been adapted for dual-fuel operation. DME was utilized as an additive to the fuel-air combination in order to increase autoignition. Natural gas and DME were premixed upstream in the engine intake manifold. The findings of the modeling indicated that the inclusion of DME makes the combustion of HCCI easier, and that raising the concentration of DME causes an increase in the amount of heat that is released at low temperatures, which accelerates the autoignition of the mixture. The modeling findings were used to determine the engine's operating limitations at various concentrations of natural gas and DME in the mixture. As the proportion of natural gas continued to rise, the working range shrank more, and the HCCI combustion became increasingly unstable.

Nieman et al. carried out computational fluid dynamics (CFD) simulations on a heavy-duty RCCI engine that was fueled with diesel and natural gas. Natural gas was utilized in lieu of gasoline as the fuel with the lowest reactivity because its higher RON caused a wider reactivity gradient between the two fuels when they were combined in the cylinder. This allowed natural gas to replace gasoline as the fuel with the lowest reactivity. An extensive speed and load range was explored, and six operating points ranging from 4 to 23 bar IMEP_n and 800 to 1800 rev/min were optimized. These six operating points reflect typical heavy-duty engine operating circumstances and were the focus of the optimization process. It was established that operating up to 13.5 bar IMEP may be reached without the use of EGR by using a compression ratio of 16:1. This was accomplished while still retaining excellent efficiency and low emissions. At 9 bar IMEP_n, natural gas/diesel operation was compared to gasoline/diesel operation, and it was discovered that in the natural gas/diesel gases, 90–95% of the UHC emissions were methane. The gasoline/diesel operation was found to produce more carbon monoxide. The findings of an investigation on the responsiveness of high-load RCCI burning to injection parameter changes revealed that accurate injection management is essential.

In another study, an experimental investigation was performed on a single-cylinder CFR engine that was operated in HCCI mode with n-heptane or natural gas fuel. The testing was focused on understanding the effects of EGR on the phasing control of the combustion process. The

gasoline mixture was pre-mixed before it was injected into the engine via the intake manifold. According to the findings of various experiments, EGR was able to bring the temperature of the bulk of the cylinder down, as well as the pressure rise rate and the peak pressure that occurred during combustion. Because of the effect that it has on the mixture's physical and chemical properties, EGR also has the effect of delaying autoignition and lengthening the burn's duration. However, the decrease in thermal efficiency was only observed in instances in which EGR caused a significant delay in the phasing of the combustion process. Although EGR was successful in lowering the peak temperatures of the cylinders and consequently the generation of NO_x, it had the opposite impact on CO and UHC emissions.

Experimental testing of RCCI combustion was also carried out by Doosje E. et al. (2014) in a six-cylinder, 8.0 L, heavy-duty engine. Natural gas was used as the low-reactivity fuel, and the exhaust gas recirculation system was cooled [26]. The engine was developed to investigate the capabilities of RCCI combustion within its operational limitations. The results of the experiments demonstrated that RCCI operation could be accomplished between 1200 and 1800 rev/min with 2 and 9 bar BMEP and engine-out NO_x and soot emissions that complied with the criteria of Euro VI. Although UHC emissions were considerable, the high temperature of the exhaust stream made it possible to use an oxidation catalytic converter. The effect of diesel injection timing on the heat release was investigated, and the results of the experiments have shown that when the beginning of injection (SOI) was sophisticated beyond 34 CAD before TDC, further advancement resulted in a delayed heat release rate, which is an indication of operation in the RCCI regime. This was observed when the SOI was advanced beyond 34 CAD before TDC. The thermal efficiency of the engine while running in RCCI mode was either equivalent to or better than that of traditional diesel combustion at all of the relevant operating points. Although total UHC levels were high, 80–85% of those levels were composed of methane. Any change in methane number (MN) within the range of 70–100 had an insignificant influence on RCCI combustion when it came to the operating conditions that were investigated.

Zoldak et al. carried out a computational investigation of RCCI combustion on a 15.0 liter heavy-duty diesel engine while utilizing natural gas as the lowest reactivity fuel. When compared to conventional diesel combustion at the same power rating condition and using the same air-fuel ratio and EGR level, RCCI ignition reduced NO_x by 17.5%, soot by 78%, and fuel consumption by 24%. The results of the study showed that the tradeoffs between fuel usage, pressure and heat release rate, cylinder pressure, and emissions formation were examined. The study's findings showed that RCCI combustion had the potential for these reductions. The findings of the modeling indicated that the quantity of diesel fuel injected directly into the cylinder was the factor that determined the reactivity of the mixture and, therefore, the combustion phasing and the pace at which the pressure rose. When compared to traditional diesel combustion, both the maximum pressure rise rate and the peak pressure were higher, but they were still within the permissible limits for maintaining the engine's durability. Both the decreased amount of mixture stratification in comparison to conventional diesel and the use of natural gas as the low-reactivity fuel contributed to the significant decrease in soot generation that occurred when the RCCI mode was utilized.

Knock and low-speed pre-ignition are two examples of abnormal combustion phenomena that can affect advanced and dual-fuel combustion concepts that use natural gas. Despite the fact that these concepts have demonstrated a great potential for efficiency improvements and emission reductions, they are also vulnerable to these phenomena (LSPI). Zaccardi J. et al. (2014) explored the prevalence of LSPI in diesel-methane CI engines, which has traditionally been linked with downsizing and boosted SI engines. However, LSPI has also been seen in

diesel-methane CI engines [27]. The incidence of LSPI in dual-fuel engines has been linked to the diesel pilot start of injection, which may fluctuate and hence impact the temperature of engine exhaust and in-cylinder trapped burnt gases. This is because the diesel-pilot start of injection can vary. However, LSPI in CI engines might have a variety of root causes that are notoriously difficult to pinpoint. Because the combustion process of CI dual-fuel engines is drastically different from that of SI engines in terms of mixture preparation and ignition, the mechanisms that cause LSPI in SI engines (overheated spark plugs, liquid fuel films, and fuel-oil interactions) might not necessarily apply to CI engines. Local spontaneous gas phase autoignition, which originates from hot residual gases and temperature heterogeneity in the combustion chamber, has been shown to be the primary cause of LSPI in CI diesel–methane engines. This has been the predominant theory about the causes of LSPI.

Kirsten M. et al. (2016) presented their research on enhanced knock detection in diesel and natural gas engines. In the study, they established a unique approach that uses the in-cylinder pressure in conjunction with the data from the knock sensor [28]. Their approach took into consideration the possibility of fluctuation in a number of different factors, including diesel rail pressure, start of injection, quantity of fuel injected, equivalency ratio, air intake temperature, methane number, compression ratio, and pressure. They used these traits to make an algorithm that can tell the difference between individual knocking cycles and normal cycles while taking into account both the premixed and diffusion stages of the CI combustion process.

ΣΥΜΠΕΡΑΣΜΑΤΑ

Ένας κινητήρας εσωτερικής καύσης, συχνά γνωστός ως κινητήρας ICE ή IC, είναι ένα είδος θερμικής μηχανής που παράγει θερμότητα συνδυάζοντας ένα καύσιμο και έναν οξειδωτικό, ο οποίος είναι συνήθως αέρας, σε μια διαδικασία καύσης που αποτελεί βασικό στοιχείο του συστήματος που ελέγχει τη ροή του ρευστού εργασίας. Ορισμένα εξαρτήματα ενός κινητήρα εσωτερικής καύσης δέχονται άμεση εφαρμογή δύναμης ως αποτέλεσμα της διαστολής των αυξημένων και υψηλής πίεσης αερίων που παράγονται ως υποπροϊόν της διαδικασίας καύσης. Τυπικά, η δύναμη παρέχεται στα έμβολα του εμβολοφόρου κινητήρα, στα πτερύγια του στροβίλου του αεριοστρόβιλου, στον ρότορα του κινητήρα Wankel ή στο ακροφύσιο του κινητήρα Wankel (κινητήρας αεριοθούμενων). Αυτή η δύναμη μεταφέρει τη χημική ενέργεια σε κινητική ενέργεια, η οποία μπορεί στη συνέχεια να χρησιμοποιηθεί για να ωθήσει, να μετακινήσει ή να τροφοδοτήσει οτιδήποτε είναι συνδεδεμένος ο κινητήρας. Σε περιπτώσεις όπου το μέγεθος ή η μάζα ενός κινητήρα ήταν πιο σχετικό, αυτό αντικατέστησε τον κινητήρα εξωτερικής καύσης ως την προτιμώμενη επιλογή.

Γύρω στο έτος 1860, ο Étienne Lenoir ανέπτυξε τον πρώτο επιτυχημένο κινητήρα εσωτερικής καύσης σε εμπορική κλίμακα. Ο Nicolaus Otto ανέπτυξε τον πρώτο εξελιγμένο κινητήρα εσωτερικής καύσης, ο οποίος έγινε γνωστός ως κινητήρας Otto, το έτος 1876. Ο κινητήρας εσωτερικής καύσης χρησιμοποιείται συχνά για να αναφέρεται σε έναν κινητήρα που έχει διαλείπουσα καύση, όπως ο πιο κοινός δίχρονος και τετράχρονος εμβολοφόρος κινητήρας, εκτός από παραλλαγές όπως ο εξάχρονος εμβολοφόρος κινητήρας και ο κινητήρας με ρότορα Wankel. Η συνεχής καύση χρησιμοποιείται σε δεύτερη κατηγορία κινητήρων εσωτερικής καύσης. Αυτά περιλαμβάνουν αεριοστρόβιλους, κινητήρες αεριοθούμενου αέρα και την πλειοψηφία των κινητήρων πυραύλων. Όλα αυτά είναι παραδείγματα κινητήρων εσωτερικής καύσης που λειτουργούν με την ίδια ιδέα που αναφέρθηκε προηγουμένως. Τα πυροβόλα όπλα είναι επίσης ένα είδος κινητήρα εσωτερικής καύσης. Ωστόσο, είναι τόσο εξειδικευμένου τύπου που συχνά θεωρούνται ότι ανήκουν σε διαφορετική κατηγορία. Αυτό συμβαίνει και με άλλα είδη οπλισμού, όπως όλμους και αντιαεροπορικά πυροβόλα. Από την άλλη πλευρά, η ενέργεια μεταφέρεται σε ένα λειτουργικό ρευστό σε κινητήρες εξωτερικής καύσης, όπως οι ατμομηχανές ή οι μηχανές Stirling, στις οποίες το ρευστό εργασίας δεν αποτελείται από, δεν αναμιγνύεται με ή δεν μολύνεται από προϊόντα καύσης. Ο αέρας, το ζεστό νερό, το νερό υπό πίεση, ακόμη και το υγρό νάτριο που έχει θερμανθεί σε ένα λέβητα μπορεί να λειτουργούν ως υγρά λειτουργίας σε κινητήρες εξωτερικής καύσης.

Αν και υπάρχουν πολλές σταθερές χρήσεις, η συντριπτική πλειονότητα των ICE χρησιμοποιούνται σε κινητές εφαρμογές και χρησιμεύουν ως η κύρια πηγή ενέργειας για μια ποικιλία οχημάτων, συμπεριλαμβανομένων των αυτοκινήτων, των αεροπλάνων και των σκαφών. Τα καύσιμα που προέρχονται από υδρογονάνθρακες, όπως το φυσικό αέριο, η βενζίνη, το ντίζελ ή η αιθανόλη, χρησιμοποιούνται συνήθως για την τροφοδοσία κινητήρων εσωτερικής καύσης (ICE). Τα ανανεώσιμα καύσιμα όπως το βιοντίζελ χρησιμοποιούνται σε κινητήρες ανάφλεξης με συμπίεση (CI), ενώ οι κινητήρες ανάφλεξης με σπινθήρα (SI) χρησιμοποιούν βιοαιθανόλη ή ETBE (οξικός αιθυλεστέρας) που δημιουργείται από βιοαιθανόλη. Ο Rudolf Diesel, ο άνθρωπος που εφηύρε τον κινητήρα ντίζελ, ήταν γνωστό ότι χρησιμοποίησε φυστικέλαιο για να τροφοδοτήσει τις μηχανές του ήδη από το έτος 1900. Τις περισσότερες φορές, τα ορυκτά καύσιμα και τα ανανεώσιμα καύσιμα αναμιγνύονται μεταξύ τους. Το υδρογόνο, το οποίο έχει πολύ περιορισμένες εφαρμογές, μπορεί να παραχθεί είτε από ορυκτά καύσιμα είτε από ανανεώσιμες πηγές ενέργειας.

Οι κινητήρες με παλινδρομικά έμβολα είναι μακράν το πιο δημοφιλές είδος συστήματος πρόωσης για αυτοκίνητα, μοτοσυκλέτες, πλοία, ακόμη και, σε μικρότερο βαθμό, ατμομηχανές. Αυτό ισχύει τόσο για χερσαία όσο και για θαλάσσια οχήματα (μερικά είναι ηλεκτρικά, αλλά τα περισσότερα χρησιμοποιούν κινητήρες ντίζελ). Αρκετοί τύποι οχημάτων, αεροπλάνων και μοτοσυκλετών χρησιμοποιούν περιστροφικούς κινητήρες που έχουν σχεδιαστεί σε μορφή Wankel. Ο όρος "οχήματα με κινητήρα εσωτερικής καύσης" αναφέρεται σε όλα αυτά τα αυτοκίνητα μαζί (ICEV).

Οι κινητήρες εσωτερικής καύσης συχνά παίρνουν τη μορφή στροβίλων καύσης ή, πιο σπάνια, κινητήρων Wankel όταν χρησιμοποιούνται σε εφαρμογές που χρειάζονται υψηλές αναλογίες ισχύος προς βάρος. Ένας κινητήρας εσωτερικής καύσης (ICE), ο οποίος μπορεί να είναι παλινδρομικός κινητήρας, χρησιμοποιείται γενικά σε μηχανοκίνητα αεροσκάφη. Οι κινητήρες αεριοθωμένων και οι στροβιλοκινητήρες, δύο διαφορετικά είδη τουρμπίνων, μπορούν να αντικαταστήσουν τους αεριοστροβίλους που χρησιμοποιούνται συνήθως σε αεροπλάνα και ελικόπτερα, αντίστοιχα. Ένα ξεχωριστό ICE μπορεί να χρησιμεύσει ως βοηθητική μονάδα ισχύος για ένα αεροπλάνο εκτός από την κύρια λειτουργία του να παρέχει πρόωση. Πολυάριθμοι τύποι μη επανδρωμένων εναέριων οχημάτων είναι εξοπλισμένα με κινητήρες Wankel.

Οι κινητήρες εσωτερικής καύσης (ICE) είναι αυτές που οδηγούν τις τεράστιες ηλεκτρικές γεννήτριες που τροφοδοτούν τα ηλεκτρικά δίκτυα. Συχνά βρίσκονται με τη μορφή στροβίλων καύσης και έχουν ηλεκτρική ισχύ που είναι κάπου κοντά στα εκατό μεγαβάτ (MW). Σε σταθμούς ηλεκτροπαραγωγής συνδυασμένου κύκλου, η εξάτμιση υψηλής θερμοκρασίας χρησιμοποιείται για να βράσει και να υπερθερμανθεί το νερό για να δημιουργήσει ατμό, ο οποίος στη συνέχεια κινεί έναν ατμοστροβίλο. Λόγω αυτού, η απόδοση είναι μεγαλύτερη από ό,τι θα ήταν αν ο κινητήρας εσωτερικής καύσης είχε χρησιμοποιηθεί μόνος του, επειδή συλλέγεται περισσότερη ενέργεια από το καύσιμο. Τα επίπεδα απόδοσης που κυμαίνονται από 50 έως 60 τοις εκατό επιτυγχάνονται συχνά από σταθμούς ηλεκτροπαραγωγής συνδυασμένου κύκλου. Οι σταθεροί κινητήρες, όπως οι κινητήρες αερίου ή οι γεννήτριες ντίζελ, χρησιμοποιούνται σε μικρότερη κλίμακα για την παροχή εφεδρικής ισχύος ή ηλεκτρικής ενέργειας σε τοποθεσίες που δεν είναι συνδεδεμένες με ηλεκτρικό δίκτυο.

Στο πλαίσιο της παρούσας διπλωματικής εργασίας μελετήσαμε το θέμα των μηχανών εσωτερικής καύσης των αυτοκινήτων και πιο συγκεκριμένα χρησιμοποιήθηκε η σχετική αγγλική βιβλιογραφία. Αυτό μας βοήθησε να εντρυφήσουμε στους τεχνικούς όρους της ειδικότητας στην αγγλική γλώσσα. Η όλη διαδικασία αποτέλεσε μια επικοινωνιακή ενασχόληση, τόσο με το αντικείμενο των μηχανών εσωτερικής καύσης, όσο και με την καθαυτό διαδικασία της μετάφρασης και σύνδεσης των διαφορετικών και πολυσύνθετων πηγών, η οποία αν και αρκετά δύσκολη λόγω των ειδικών όρων, κέντρισε το ενδιαφέρον μας και μας βοήθησε στο να εμπλουτίσουμε τις γνώσεις μας.

Εν κατακλείδι, ελπίζουμε ότι η παρούσα διπλωματική εργασία θα φανεί χρήσιμη σε φοιτητές και σε συναδέλφους μηχανολόγους μηχανικούς που θα τους βοηθήσει να ασχοληθούν με τον συγκεκριμένο τομέα στην αγγλική γλώσσα.

ΒΙΒΛΙΟΓΡΑΦΙΑ

- [1] "electricalworkbook.com," [Online]. Available: <https://electricalworkbook.com/ic-engine/>. [Accessed 25 11 2022].
- [2] "blog.amsoil.com," [Online]. Available: <https://blog.amsoil.com/what-do-piston-rings-do/>. [Accessed 25 11 2022].
- [3] "24mx.eu," [Online]. Available: https://www.24mx.eu/product/wossner-piston-ring_pid-PM-0000950?v=862&gclid=CjwKCAiA7IGcBhA8EiwAFfUDsXEFy5WuRgQzfw4bYe_Z54gL14GB3C9L2luTKcOkAfcV1U6B4K9ZlxoCeucQAvD_BwE&gclsrc=aw.ds. [Accessed 25 11 2022].
- [4] "cas-shop," [Online]. Available: <https://www.cas-shop.com/en/product/piston-ring-oil-scraper-5mm/>. [Accessed 25 11 2022].
- [5] "hubauer-shop," [Online]. Available: https://www.hubauer-shop.de/en/connecting-rod-11248570833.html?refID=HU89436225554&gclid=CjwKCAiA7IGcBhA8EiwAFfUDsZKK0G-SIL5T4IU9wRvr8bSLiSRGGT38zfJ8A6Duxrsf4LtLbr4wexoCyCUQAvD_BwE. [Accessed 25 11 2022].
- [6] "pngtree.com," [Online]. Available: https://pngtree.com/freepng/engine-piston-rod-and-crank-assembly_6951834.html. [Accessed 25 11 2022].
- [7] "www.newkidscar.com," [Online]. Available: <https://www.newkidscar.com/engine-construction/engine-flywheel-construction/>. [Accessed 25 11 2022].
- [8] Weeks L. H., "Automobile Biographies: An Account of the Lives and the Work of Those who Have Been Identified with the Invention and Development of Self-propelled Vehicles on the Common Roads," *Monograph Press*, p. 89, 1904.
- [9] Borth C. , "Masters of Mass Production," *Bobbs-Merrill Company, Indianapolis*, p. 152, 1945.
- [10] Wise D. B. , "Daimler: Founder of the Four-Wheeler," in *Northey, Tom, ed. World of Automobiles (London: Orbis, 1974)*, vol. 5, no. 482.
- [11] Boothroyd D. , "Forgotten Hero: The man who invented the two-stroke engine," *The VU*, 2004.
- [12] Haug G. , "Gottlieb Daimler - Der Traum vom Fahren: Historischer Roman," *Masken-Verlag Friedrich Willmann*, pp. ISBN 978-3939500278, 2010.
- [13] Cummins C., "Diesel's Engine: Volume 1: From Conception To 1918," *Wilsonville, OR: Carnot Press*, pp. ISBN 978-0-917308-03-1, 1993.
- [14] Hawthorne W. , "Harry Ralph Ricardo 26 January 1885 -- 18 May 1974," *Biographical Memoirs of Fellows of the Royal Society*, vol. 22, p. doi:10.1098/rsbm.1976.0016. S2CID 72679446., 1976.
- [15] "mechomotive.com," [Online]. Available: <https://mechomotive.com/four-stroke-si-engine/>. [Accessed 9 11 2022].

- [16] Cameron K., "www.cycleworld.com," 2015. [Online]. Available: <https://www.cycleworld.com/2015/04/06/two-stroke-motorcycle-engines-explained-tech-talk-by-kevin-cameron/>. [Accessed 9 11 2022].
- [17] "www.carblogindia.com," [Online]. Available: <https://www.carblogindia.com/types-of-engine-layouts-inline-v-vr-rotary-and-more/>. [Accessed 9 11 2022].
- [18] "arb.ca.gov," [Online]. Available: <https://ww2.arb.ca.gov/our-work/programs/new-vehicle-and-engine-certification>. [Accessed 9 11 2022].
- [19] Laxmikant J. & Siddappa P., "An Up-Thrust for Knowledge Thermal Engineering -i Written by Popular Authors of Text Books of Technical Publications Covers Entire Syllabus Question -Answer Format Exact Answers & Solutions Important Points," 2021.
- [20] "engineers-dream," [Online]. Available: <https://www.engineers-dream.com/2021/12/dry-sump-lubrication-systems.html>. [Accessed 30 11 2022].
- [21] "en.wikipedia.org," [Online]. Available: https://en.wikipedia.org/wiki/Ring_oiler. [Accessed 30 11 2022].
- [22] Najt P.M., Foster D.E. , "Compression-ignited homogeneous charge combustion," *SAE Technical Paper No. 830264*, 1983.
- [23] Epping K., Aceves S., Bechtold R., Dec J.E., "The potential of HCCI combustion for high efficiency and low emissions," *SAE Technical Paper No. 2002-01-1923*, 2002.
- [24] Sjöberg M., Dec J.E. , "An investigation of the relationship between measured intake temperature," *BDC temperature, and combustion phasing for premixed and DI HCCI engines. SAE Technical Paper No. 2004-01-1900*, 2004.
- [25] Christensen M., Johansson B. , "Supercharged homogeneous charge compression ignition (HCCI) with exhaust gas recirculation and pilot fuel," *SAE Technical Paper No. 2000-01-1835*, 2000.
- [26] Christensen M., Johansson B., Einewall P., "Homogeneous charge compression ignition (HCCI) using iso-octane, ethanol and natural gas-a comparison with spark ignition operation," *SAE Technical Paper No. 972874*, 1997.
- [27] Chang K., Lavoie G.A., Babajimopoulos A., Filipi Z., Assanis D.N., "Control of a multi-cylinder HCCI engine during transient operation by modulating residual gas fraction to compensate for wall temperature effects," *SAE Technical Paper No. 2007-01-0204*, 2007.
- [28] Dec J.E., Yang Y., Dernet J., Ji C., "Effects of gasoline reactivity and ethanol content on boosted, premixed and partially stratified low-temperature gasoline combustion (LTGC)," *SAE Int J Engines* , vol. 8, no. 3, p. 935–955, 2015.
- [29] Yang Y., Dec J.E., Dronniou N., Cannella W., "Boosted HCCI combustion using low-octane gasoline with fully premixed and partially stratified charges.," *SAE Int J Engines* , vol. 5, p. 1075–1088, 2012.
- [30] Lawler B., Splitter D., Szybist J., Kaul B., "Thermally stratified compression ignition: a new advanced low temperature combustion mode with load flexibility," *Appl Energy* , p. 122–132, 2017.

- [31] Kokjohn S.L., Reitz R.D. , "Reactivity controlled compression ignition and conventional diesel combustion: a comparison of methods to meet light-duty NOx and fuel economy targets," *Int J Engine Res* , vol. 14, no. 5, p. 452–468, 2013.
- [32] Aceves S.M., Smith J.R., Westbrook C.K., Pitz W.J. , "Compression ratio effect on methane HCCI combustion," *J Eng Gas Turbines Power* , vol. 121, no. 3, p. 569–574, 1999.
- [33] Olsson J.O., Tunestål P., Johansson B., Fiveland S., Agama R., Willi M., Assanis D.N. , "Compression ratio influence on maximum load of a natural gas fueled HCCI engine," *SAE Technical Paper No. 2002-01-0111*, 2002.
- [34] Yap D., Peucheret S.M., Megaritis A., Wyszynski M.L., Xu H. , "Natural gas HCCI engine operation with exhaust gas fuel reforming," *Int J Hydrogen Energy*, vol. 31, no. 5, p. 587–595, 2006.
- [35] Papagiannakis R.G., Hountalas D.T. , "Combustion and exhaust emission characteristics of a dual fuel compression ignition engine operated with pilot diesel fuel and natural gas," *Energy Convers Manag* , vol. 45, p. 2971–2987, 2004.
- [36] Doosje E., Willems F., Baert R. , "Experimental demonstration of RCCI in heavy-duty engines using diesel and natural gas," *SAE Technical Paper No. 2014-01-1318*, 2014.
- [37] Zaccardi J., Serrano D., "A comparative low speed pre-ignition (LSPI) study in downsized SI gasoline and CI diesel-methane dual fuel engines," *SAE Int J Engines* , vol. 7, no. 4, p. 1931–1944, 2014.
- [38] Kirsten M., Pirker G., Redtenbacher C., Wimmer A., "Advanced knock detection for diesel/natural gas engine operation," *SAE Int J Engines* , vol. 9, no. 3, p. 1571–1583, 2016.
- [39] mototriti, «www.mototriti.gr,» [Ηλεκτρονικό]. Available: https://www.mototriti.gr/data/news/preview_news/Ola-osa-prepei-na-ksereis-gia-ta-pistoniasoy_119479.asp. [Πρόσβαση 9 10 2021].
- [40] indiamart, "www.indiamart.com," [Online]. Available: <https://www.indiamart.com/proddetail/automobile-car-engine-14834724791.html>. [Accessed 9 10 2021].
- [41] indiamart, "www.indiamart.com," [Online]. Available: <https://www.indiamart.com/proddetail/marine-engine-2190615430.html>. [Accessed 9 10 2021].
- [42] Obert E., *Internal Combustion Engines*, Scranton, PA.: International Textbook Co., 1950.
- [43] Schwitzer T., "“Introduction To Turbochargers”," *Schwitzer Turbochargers*, 1991.
- [44] dieselgeneratortech, "www.dieselgeneratortech.com," [Online]. Available: <https://www.dieselgeneratortech.com/diesel-engines/how-does-engine-cooling-system-work.html>. [Accessed 9 10 2021].
- [45] modelengineneews, "modelengineneews.org," [Online]. Available: <http://modelengineneews.org/rsch/classic.html>. [Accessed 9 10 2021].
- [46] Arcoumanis, C., *Internal Combustion Engines*, London, England: Academic Press, 1988.

- [47] Benson R. & Whitehouse N., *Internal Combustion Engines*, New York: Pergamon Press, 1979.
- [48] Heywood J. B., *Internal Combustion Engine Fundamentals*, New York: McGraw-Hill, 2018.
- [49] Shi Y. H. Ge & Reitz R. , *Computational Optimization of Internal Combustion Engines*, London, England: Springer-Verlag, 2011.
- [50] Stone R., *Introduction to Internal Combustion Engines*, Warrendale, PA: SAE International, 2012.
- [51] Bunce M. & Blaxill H., "Sub-200 g/kWh BSFC on a Light Duty Gasoline Engine," *SAE Technical Paper* , 2016.
- [52] Qiao A. & Wu, X., "Research on the New Ignition Control System of Lean- and Fast-Burn SI Engines," *SAE Technical Paper*, 2008.
- [53] Attard W., Toulson E., Fraser E., Parsons, P., " A Turbulent Jet Ignition Pre-Chamber Combustion System for Large Fuel Economy Improvements in a Modern Vehicle Powertrain," *SAE Technical Paper* , Vols. 2010-01-1457, pp. doi:10.4271/2010-01-1457, 2010.
- [54] Cao Y. & Li L., "A novel closed loop control based on ionization current in combustion cycle at cold start in a gdi engine," *SAE Technical Paper* , Vols. 2012-01-1339, pp. doi:10.4271/2012-01-1339., 2012.
- [55] Sens M., Binder E., Reinicke P.B., Riess M., Stappenbeck T., Woebke, M., "Pre- Chamber Ignition and Promising Complementary Technologies," *27th Aachen Colloquium Automobile and Engine Technology*, 2018.
- [56] Attard W., Kohn J., Parsons P., "Ignition Energy Development for a Spark Initiated Combustion System Capable of High Load, High Efficiency and Near Zero NOx Emissions," *SAE Journal Paper JSAE 20109088*, 2010.
- [57] Attard W., Blaxill H., "A Gasoline Fueled Pre-Chamber Jet Ignition Combustion System at Unthrottled Conditions," *SAE Technical Paper 2012-01-0386*, pp. doi:10.4271/2012-01-0386., 2012.
- [58] Chinnathambi P., "RANS Based Multidimensional Modeling of an Ultra-Lean Burn Pre-Chamber Combustion System with Auxiliary Liquid Gasoline Injection," Vols. 10.4271/2015-01-0386. , 2015.
- [59] P. R.P., "Motor compressor apparatus". Patent US Patent 1,657,641, 1928.
- [60] Toutant W.T., "The Worthington–Junkers free-piston air compressor," *Journal of the American Society of Naval Engineers*, vol. 64, no. 3, p. 583–594, 1952.
- [61] Zhang C. & Sun Z., "Trajectory-based combustion control for renewable fuels in free piston engines," *Applied Energy*, vol. 187, pp. 72-83, 2017.
- [62] Virsik R., "Free piston linear generator in comparison to other range-extender technologies," *World Electric Vehicle Journal*, 2013.

- [63] Heron A. and Rinderknecht F., "Comparison of Range Extender technologies for Battery Electric Vehicles," in *Eighth International Conference and Exhibition on Ecological Vehicles and Renewable Energies (EVER), Monte Carlo, Monaco*, 2013.
- [64] Kosaka H., Akita T., Moriya K., Goto S., Hotta Y., Umeno, T., Nakakita K. , "Development of Free Piston Engine Linear Generator System Part 1," - *Investigation of Fundamental Characteristics*, pp. <https://doi.org/10.4271/2014-01-1203>, 2014.
- [65] Hanipah M. R., Mikalsen R., Roskilly A. P., « Recent commercial free-piston engine developments for automotive applications.»,» *Appl Therm Eng*, τόμ. 75, pp. 493-503 <https://doi.org/10.1016/j.applthermaleng.2014.09.039>, 2015.
- [66] Smallbone A. J., Roy S., Shivaprasad K. V., Jia B., Roskilly A. P., "The development and testing of a free-piston engine generator for hybrid electric vehicle applications," *Institute of Mechanical Engineers*, 2019.
- [67] Seabrook J., Dalby J., Shoji K., Inoue A., , "Virtual Calibration to Improve the Design of a Low Emissions Gasoline Engine," *International Conference on Calibration Methods and Automotive Data Analytics*, 2019.
- [68] Wahbi, A., Tsolakis, A., Herreros, J., "Emissions Control Technologies for Natural Gas Engines," *Natural Gas Engines*, , pp. 359–379, doi:10.1007/978-981-13-3307-1_13., 2018.
- [69] Raj B. A., "A review of mobile and stationary source emissions abatement technologies for natural gas engines," *Johnson Matthey Tech*, vol. 60, pp. 228-235, doi:10.1595/205651316x692554, 2016.
- [70] Tsinoglou D. N., Koltsakis G. C., Peyton Jones, J. C., "Oxygen storage modeling in three-way catalytic converters," *Industrial & engineering chemistry research*, vol. 41, no. 5, pp. 1152–1165, doi:10.1021/ie010576c, 2002.,.
- [71] Montenegro G. & Onorati A., "1D Thermo-Fluid Dynamic Modeling of Reacting Flows inside Three-Way Catalytic Converters," *SAE Int. J. Engines* , vol. 2, no. 1, pp. 1444–1459,, doi:10.4271/2009-01-1510., 2009.
- [72] Zeng F. & Hohn, K. L., "Modeling of three-way catalytic converter performance with exhaust mixture from natural gas-fueled engines," *Applied Catalysis B: Environmental*, vol. 182, pp. 570-579, doi: 10.1016/j.apcatb.2015.10.004, 2016.
- [73] Tsinoglou D. N., Eggenschwiler P. D., Thurnheer T., Hofer P. , "A simplified model for natural-gas vehicle catalysts with honeycomb and foam substrates," *Proceedings of the Institution of Mechanical Engineers Part D: Journal of Automobile Engineering*, vol. 223, no. 6, p. 819–834 doi:10.1243/09544070JAUTO1095, 2009.
- [74] Maio D. M., Beatrice C., Fraioli V., Golini S., Rutigliano F. G., Riccardi M. , "Modeling of three-way catalyst dynamics during fast transient operation for a CNG heavy-duty engine," *Institute of Mechanical Engineers*, 2019.
- [75] Southcott M. & Evans G., "Forecasting the implications of Euro 7 on the powertrain supply chain," *Institute of Mechanical Engineers*, 2019.

- [76] Buckendale L.R., Stanton D.W., Stanton D.W., "Systematic Development of Highly Efficient and Clean Engines to Meet Future Commercial Vehicle Greenhouse Gas Regulations," *SAE Int. 2013-01-2421*, pp. doi:10.4271/2013-01-2421., 2013.
- [77] Johnson T., "Vehicular Emissions in Review," *SAE Int. J. Engines*, vol. 9, no. 2, pp. doi:10.4271/2016-01-0919., 2016.
- [78] M. R., "Supercharged Engine". United States Patents Patent (US 2 817 322), 1957.
- [79] Guan W., Pedrozo V., Zhao H., Ban Z. Lin T., "Investigation of EGR and Miller Cycle for NO_x Emissions and Exhaust Temperature Control of a Heavy-Duty Diesel Engine," *SAE Tech. Pap.*, pp. doi:10.4271/2017-01-2227, 2017.
- [80] Zhao C., Yu G., Yang J., Bai M., Shang, F., "Achievement of Diesel Low Temperature Combustion through Higher Boost and EGR Control Coupled with Miller Cycle," pp. doi:10.4271/2015-01-0383, 2015.
- [81] Ban Z. , Guan. W., Wang X., Zhao H., Lin T., Zheng Z., "Effective engine technologies for optimum efficiency and emission control of the heavy-duty diesel engine," *Institute of Mechanical Engineers*,, 2019.
- [82] Concawe Report , "Phase 1: Effect of fuel octane on the performance of two Euro 4 Gasoline Passenger Cars," *Concawe Report* , 2016.
- [83] Stradling R. , "Effect of Octane on Performance, Energy Consumptions and emissions of two Euro 4 passenger cars," *Transportation Research Procedia*, 2016.
- [84] Williams J. , "Effect of Octane on the performance of Euro 5 and Euro 6 gasoline passenger cars," *SAE paper no. 2017-01-0811*, 2017.
- [85] Hamje H. , Williams J., Kollbeck A., Mirabella W., "Improvements in drive-cycle fuel consumption by co-optimisation of engine and fuel," *Institute of Mechanical Engineers*, 2019.
- [86] Vorraro G., Islam R., Turner M., Turner J.W.G, "Application of a rotary expander as an energy recovery system for a modern Wankel engine," *Institute of Mechanical Engineers*.
- [87] Whitaker P., Kapus P., Ogris M., Hollerer P., "Measures to Reduce Particulate Emissions from Gasoline DI engines," *SAE Technical Paper 2011-01-1219* , pp. doi: 10.4271/2011-01-1219, 2011.
- [88] Kim J., Cho Y., Park S., "The Next Generation 1.6L Naturally Aspirated Gasoline Engine from Hyundai-Kia," *26th Aachen Colloquium Automobile and Engine Technology 2017*, 2017.
- [89] carscoops, "www.carscoops.com," [Online]. Available: <https://www.carscoops.com/2014/05/toyota-shows-new-gasoline-engine/>. [Accessed 19 10 2021].
- [90] schaeffler-events, "schaeffler-events.com," [Online]. Available: <https://schaeffler-events.com/symposium/lecture/h6/index.html>. [Accessed 19 10 2021].
- [91] gazeo, "gazeo.com," [Online]. Available: <https://gazeo.com/up-to-date/reportages-interviews-road-tests/road-tests/Scania-G340-LNG-boosted-range,report,9854.html>. [Accessed 19 10 2021].

[92] environmental, "www.environmental," [Online]. Available: <https://www.environmental-expert.com/products/johnson-matthey-model-twc-three-way-catalysts-182807>. [Accessed 19 10 2021].